

Printed Circuit Board Connectors

Introduction

38999 Series I, II, II & 26482 II



Introduction

For many years, Aero Electric has been making mil circular connectors, and for nearly just as long, we have been supplying them with pc tail contacts. From all the applications we have supported with our pc tail connectors, and all the engineers we have worked with, we have finally taken all that we have learned and created a full product offering.

This product line is made in accordance with MIL-DTL-38999 and MIL-DTL-26482. This family of connectors offers multiple receptacle shell styles, and is available in several materials, such as aluminum, stainless steel, and for extreme corrosion environments, aluminum nickel bronze. The plating options are extensive as well, and that includes electroless nickel, olive drab cadmium, bright cadmium, hard anodized, black nickel, Zinc nickel, and Teflon nickel.

Features

1. Clinch nut options for more secure mounting to the panel
2. Stand-off with helicoids for best practice when supporting the pcb to the connector
3. Shell to PC board connection to allow for another ground path, if needed
4. Slots on the shells to allow for aqueous wash to run through and clean post wave soldering

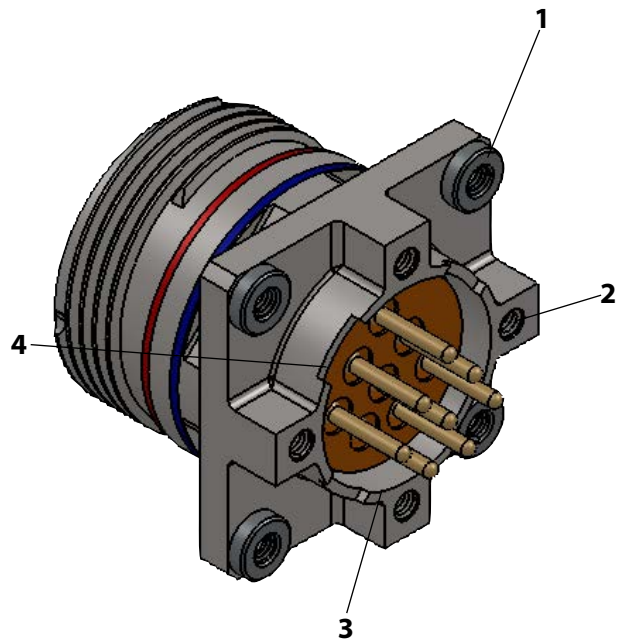
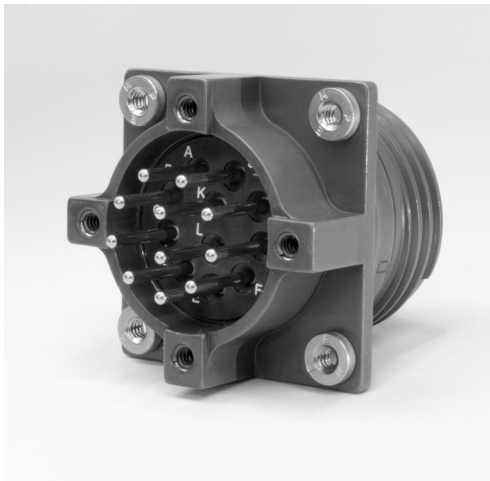

AEP65-104

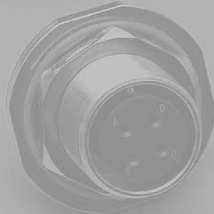

Printed Circuit Board Connectors Table of Contents 38999 Series I, II, III & 26482 II

Table of Contents

AEP65-101, AEP65-102	167-168
AEP65-103, AEP65-104	169-170
AEP65-105, AEP65-106	171-172
AE65-505	173-174
AE65-255	175-176
AE6520	177-178
AE6524	179-180
AEP45-101, AEP45-102	181-182
AEP45-103, AEP45-104	183-184
AEP45-105, AEP45-106	185-186
AEP55-101, AEP55-102	187-188
AEP55-103, AEP55-104	189-190
AEP55-105, AEP55-106	191-192
MIL-STD 1560 Insert Arrangement List	193
MIL-STD 1560 Insert Arrangement Views	194-208
AEP15-101, AEP15-102	209-210
AEP15-103, AEP15-104	211-212
AEP15-105, AEP15-106	213-214
MIL-STD 1669 Insert Arrangement List	215
MIL-STD 1669 Insert Arrangement Views	216-228
PC Tail Lengths	229-234

MIL-DTL-38999 Series III Rear, Wall Mounting Receptacle AEP65-101, AEP65-102



Part Number Development

Aero Prefix	AEP65-	101-	F	E	35	P	A-	***
Shell Type	<ul style="list-style-type: none"> 101 = Wall Mount 102 = Wall Mount w/ Clinch Nuts 							
Material Finish	<ul style="list-style-type: none"> F = Aluminum, Electroless Nickel B = Aluminum, Olive Drab Cadmium Over Nickel BN = Aluminum, Black Nickel, (RoHS) T = Aluminum, Teflon Nickel, (RoHS), (consult factory for availability) Z = Aluminum, Black Zinc Nickel, (RoHS), (consult factory for availability) 							
Shell Size	A=9, B=11, C=13, D=15, E=17, F=19, G=21, H=23, J=25							
Insert Arrangement	Per MIL-STD-1560. See Pages 194 Thru 208 for Insert Selection.							
Contact Style	<ul style="list-style-type: none"> P = Pin S = Socket 							
Polarization (Keying)	A, B, C, D or E = Alternate							
Options (Aero Modification Number)	***Consult factory for other modifications							

AEP65-101 and -102 Dimensional Data

SHELL SIZE	MS SHELL CODE	A		B		C*		D*		E*		F THREAD TRIPLE START	ØH MAX	
		INCH ±.012	MM ± 0.26	INCH ±.010	MM ± 0.26	INCH ±.010	MM ± 0.26	INCH ±.008	MM ± 0.20	INCH ±.008	MM ± 0.20		INCH	MM
9	A	.937	23.80	.719	18.26	.594	15.09	.216	5.49	.128	3.25	.6250-.1P-.3L	.460	11.68
11	B	1.031	26.20	.812	2.062	.719	18.26	.194	4.93	.128	3.25	.7500-.1P-.3L	.586	14.88
13	C	1.126	28.60	.906	23.01	.812	20.62	.194	4.93	.128	3.25	.8750-.1P-.3L	.710	18.03
15	D	1.220	31.00	.969	24.61	.906	23.01	.194	4.93	.128	3.25	1.000-.1P-.3L	.834	21.18
17	E	1.311	33.30	1.062	26.97	.969	24.61	.194	4.93	.128	3.25	1.187-.1P-.3L	.960	24.38
19	F	1.437	36.50	1.156	29.37	1.062	26.97	.194	4.93	.128	3.25	1.250-.1P-.3L	1.070	27.18
21	G	1.563	39.70	1.250	31.75	1.156	29.36	.194	4.93	.128	3.25	1.375-.1P-.3L	1.186	30.12
23	H	1.689	42.90	1.375	34.93	1.250	31.75	.242	6.15	.154	3.91	1.500-.1P-.3L	1.320	33.53
25	J	1.811	46.00	1.500	38.10	1.375	34.93	.242	6.15	.154	3.91	1.625-.1P-.3L	1.446	36.73

* for AEP65-101

Alternate PC Tail diameters and lengths are available. Refer to PC Tail Specification section starting on 229-234 for further information, or consult Conesys/Aero Electric Connector for application support.

Standard PC Tail Diameters

CONTACT SIZE	ØJ ±.001
22D	.019
20	.019
16	.062



AEP65-101 Receptacle Connector, Wall Mount

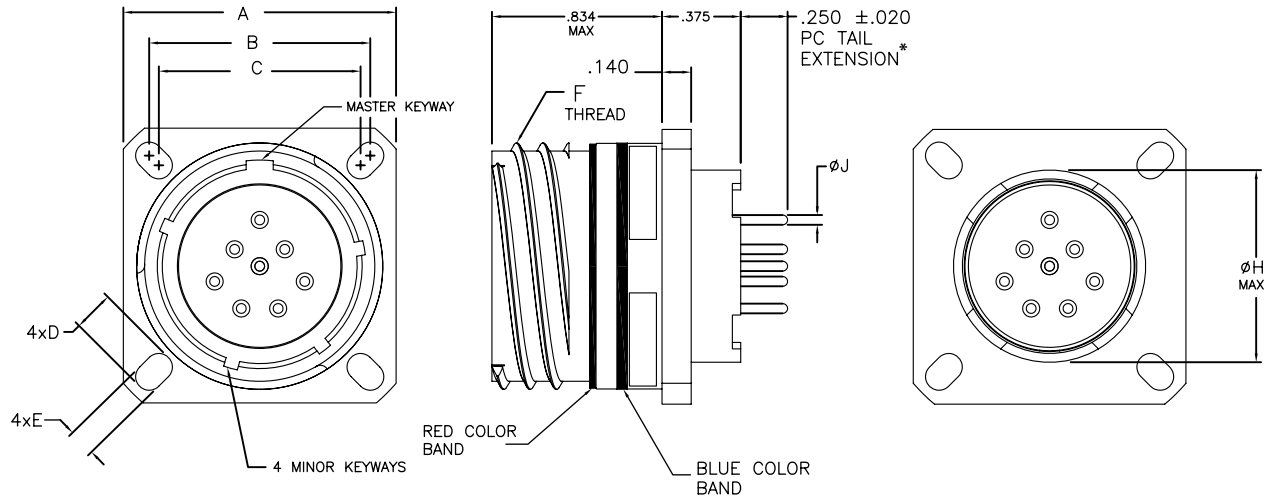

AEP65-102 Receptacle Connector, Wall Mount with Clinch Nuts

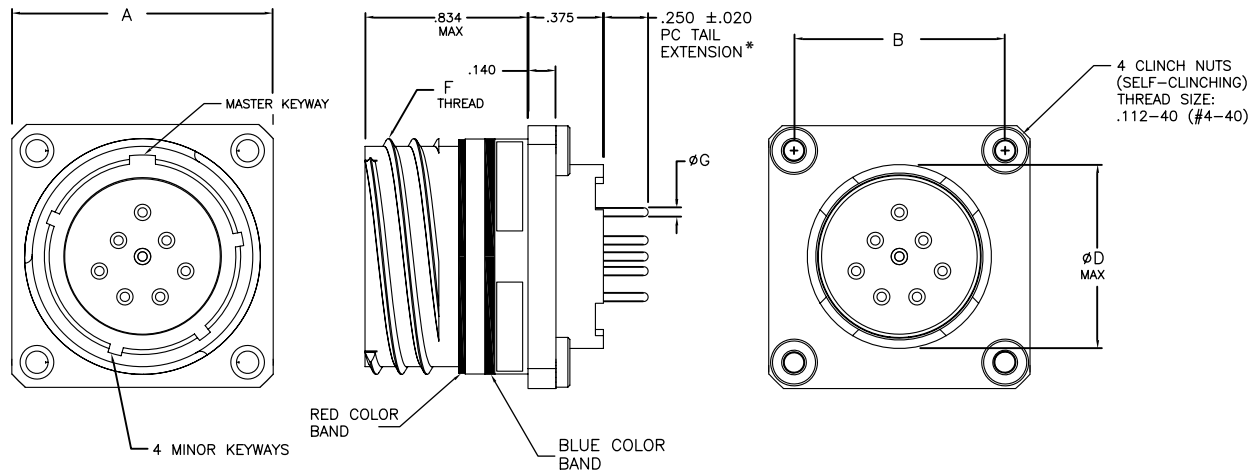

AEP65-101

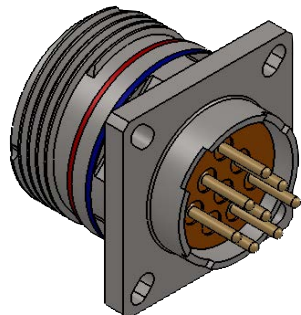

AEP65-102

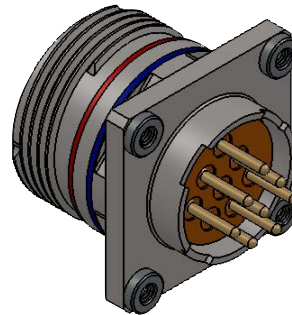

* Standard PC tail extension length. For optional lengths, 229-234 for further information

MIL-DTL-38999 Series III Rear, Wall Mounting Receptacle AEP65-103, AEP65-104



Part Number Development

Aero Prefix	AEP65-	103-	F	E	35	P	A-	***
Shell Type	<p>103 = Wall Mount w/ Dual Flange 104 = Wall Mount w/ Dual Flange & Clinch Nut</p>							
Material Finish	<p>F = Aluminum, Electroless Nickel B = Aluminum, Olive Drab Cadmium Over Nickel BN = Aluminum, Black Nickel, (RoHS) T = Aluminum, Teflon Nickel, (RoHS), (consult factory for availability) Z = Aluminum, Black Zinc Nickel, (RoHS), (consult factory for availability)</p>							
Shell Size	<p>A=9, B=11, C=13, D=15, E=17, F=19, G=21, H=23, J=25</p>							
Insert Arrangement	<p>Per MIL-STD-1560. See Pages 194 Thru 208 for Insert Selection.</p>							
Contact Style	<p>P = Pin S = Socket</p>							
Polarization (Keying)	<p>A, B, C, D or E = Alternate</p>							
Options (Aero Modification Number)	<p>***Consult factory for other modifications</p>							

AEP65-103 and -104 Dimensional Data

SHELL SIZE	MS SHELL CODE	A		B		C		D*		E*		F THREAD TRIPLE START	ØH MAX		J*	
		INCH	MM	INCH	MM	INCH	MM	INCH	MM	INCH	MM		INCH	MM	INCH	MM
		±.012	± 0.26	±.010	± 0.26	±.010	± 0.26	±.008	± 0.20	±.008	± 0.20		INCH	MM	±.005	± 0.13
9	A	.937	23.80	.719	18.26	.594	15.09	.216	5.49	.128	3.25	.6250-1P-.3L	.460	11.68	.556	14.12
11	B	1.031	26.20	.812	2.062	.719	18.26	.194	4.93	.128	3.25	.7500-1P-.3L	.586	14.88	.686	17.42
13	C	1.126	28.60	.906	23.01	.812	20.62	.194	4.93	.128	3.25	.8750-1P-.3L	.710	18.03	.802	20.37
15	D	1.220	31.00	.969	24.61	.906	23.01	.194	4.93	.128	3.25	1.000-1P-.3L	.834	21.18	.927	23.55
17	E	1.311	33.30	1.062	26.97	.969	24.61	.194	4.93	.128	3.25	1.187-1P-.3L	.960	24.38	1.048	26.62
19	F	1.437	36.50	1.156	29.37	1.062	26.97	.194	4.93	.128	3.25	1.250-1P-.3L	1.070	27.18	1.126	28.60
21	G	1.563	39.70	1.250	31.75	1.156	29.36	.194	4.93	.128	3.25	1.375-1P-.3L	1.186	30.12	1.250	31.75
23	H	1.689	42.90	1.375	34.93	1.250	31.75	.242	6.15	.154	3.91	1.500-1P-.3L	1.320	33.53	1.387	35.23
25	J	1.811	46.00	1.500	38.10	1.375	34.93	.242	6.15	.154	3.91	1.625-1P-.3L	1.446	36.73	1.500	38.10

Standard PC Tail Diameters

Alternate PC Tail diameters and lengths are available. Refer to PC Tail Specification section starting on 229-234 for further information, or consult Conesys/Aero Electric Connector for application support.

CONTACT SIZE	ØG ±.001
22D	.019
20	.019
16	.062

AEP65-103 Receptacle Connector, Wall Mount with Dual Flange

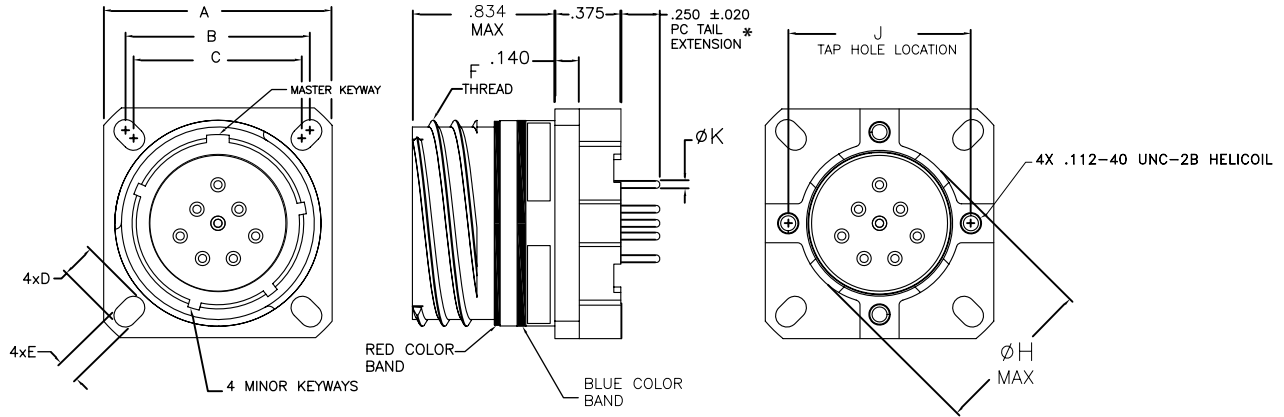

AEP65-104 Receptacle Connector, Wall Mount with Dual Flange and Clinch Nuts

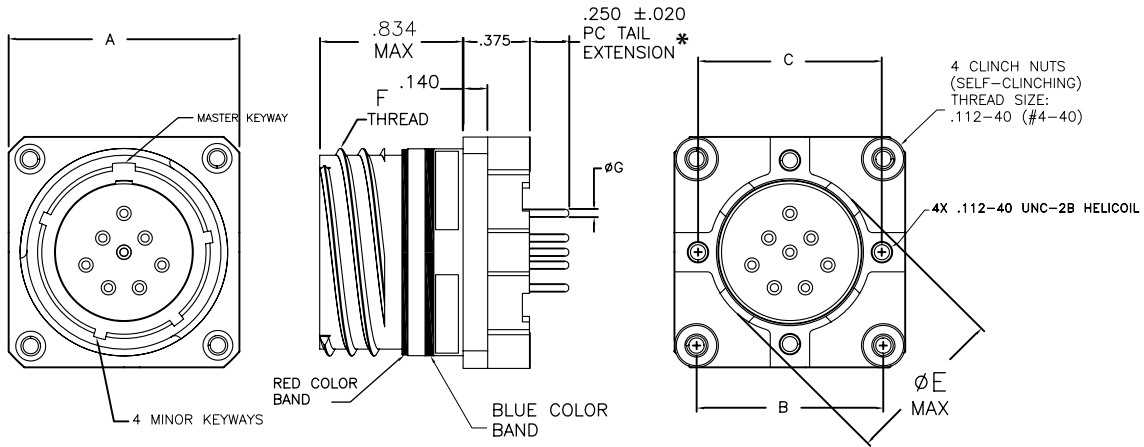

AEP65-103

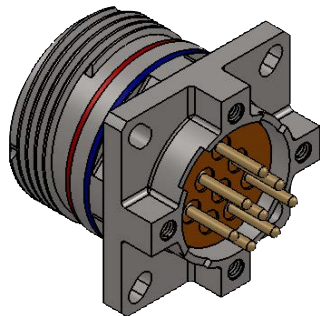

AEP65-104

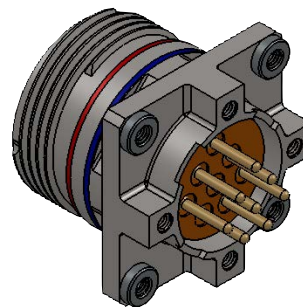

* Standard PC tail extension length. For optional lengths, 229-234 for further information

MIL-DTL-38999 Series III Rear, Wall Mounting Receptacle AEP65-105, AEP65-106



Part Number Development

Aero Prefix	AEP65-	105-	F	E	35	P	A-	***
Shell Type								
105 = Wall Mount w/ Dual Flange								
106 = Wall Mount w/ Dual Flange & Clinch Nuts								
Material Finish								
F = Aluminum, Electroless Nickel								
B = Aluminum, Olive Drab Cadmium Over Nickel								
BN = Aluminum, Black Nickel, (RoHS)								
T = Aluminum, Teflon Nickel, (RoHS), (consult factory for availability)								
Z = Aluminum, Black Zinc Nickel, (RoHS), (consult factory for availability)								
Shell Size								
A=9, B=11, C=13, D=15, E=17, F=19, G=21, H=23, J=25								
Insert Arrangement								
Per MIL-STD-1560. See Pages 194 Thru 208 for Insert Selection.								
Contact Style								
P = Pin S = Socket								
Polarization (Keying)								
A, B, C, D or E = Alternate								
Options (Aero Modification Number)								
***Consult factory for other modifications								

AEP65-105 and -106 Dimensional Data

SHELL SIZE	MS SHELL CODE	A		B MTG. FLAT		C HEX		D		E THREAD	F THREAD TRIPLE START	G (AEP65-106)		ØH MAX	
		INCH ±.016	MM ± 0.40	INCH +.004 -.006	MM +0.10 -0.15	INCH	MM	INCH +.024 -.000	MM +0.60 -0.00			INCH ±.005	MM ± 0.13	INCH	MM
9	A	1.063	27.00	.651	16.53	.945 .859	24.00 21.82	.555	14.10	M17x1.0-6g.100R	.6250-1P-.3L	.556	14.12	.460	11.68
11	B	1.252	31.80	.751	19.07	1.063 .984	27.00 24.99	.555	14.10	M20x1.0-6g.100R	.7500-1P-.3L	.686	17.42	.586	14.88
13	C	1.374	34.90	.938	23.82	1.260 1.172	32.00 29.77	.555	14.10	M25x1.0-6g.100R	.8750-1P-.3L	.802	20.37	.710	18.03
15	D	1.500	38.10	1.062	26.97	1.417 1.296	36.00 32.91	.555	14.10	M28x1.0-6g.100R	1.000-1P-.3L	.927	23.55	.834	21.18
17	E	1.626	41.30	1.187	30.15	1.457 1.422	37.00 36.12	.555	14.10	M32x1.0-6g.100R	1.187-1P-.3L	1.048	26.62	.960	24.38
19	F	1.811	46.00	1.312	33.32	1.614 1.546	41.00 39.26	.555	14.10	M35x1.0-6g.100R	1.250-1P-.3L	1.126	28.60	1.070	27.18
21	G	1.937	49.20	1.437	36.50	1.811 1.672	46.00 42.47	.555	14.10	M38x1.0-6g.100R	1.375-1P-.3L	1.250	31.75	1.186	30.12
23	H	2.063	52.40	1.562	39.67	1.969 1.796	50.00 45.61	.555	14.10	M41x1.0-6g.100R	1.500-1P-.3L	1.387	35.23	1.320	33.53
25	J	2.189	55.60	1.687	42.85	2.017 1.939	51.23 49.25	.555	14.10	M44x1.0-6g.100R	1.625-1P-.3L	1.500	38.10	1.446	36.73

Alternate PC Tail diameters and lengths are available. Refer to PC Tail Specification section starting on 229-234 for further information, or consult Conesys/Aero Electric Connector for application support.

Standard PC Tail Diameters

CONTACT SIZE	ØJ ±.001
22D	.019
20	.019
16	.062

AEP65-105 Receptacle Connector, Wall Mount with Dual Flange

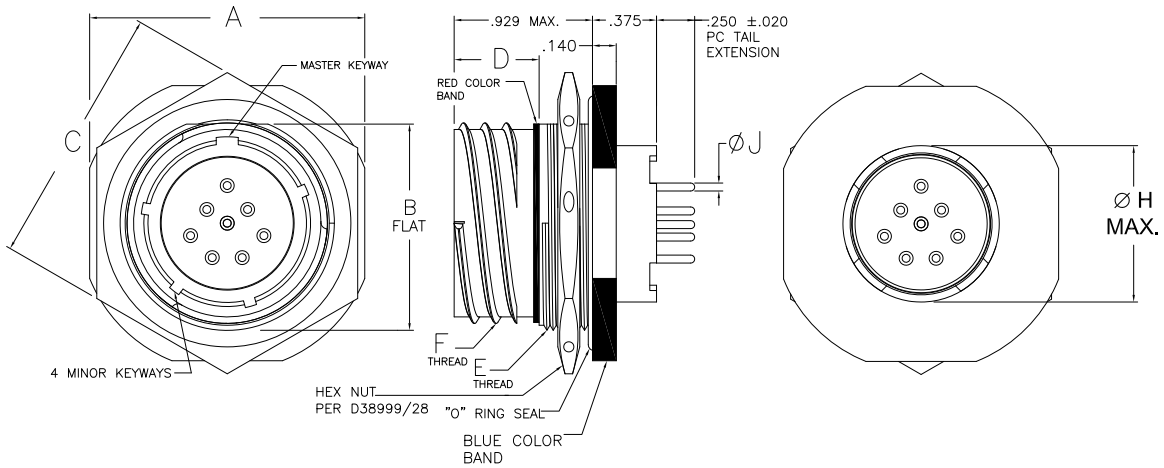

AEP65-106 Receptacle Connector, Wall Mount with Dual Flange and Clinch Nuts

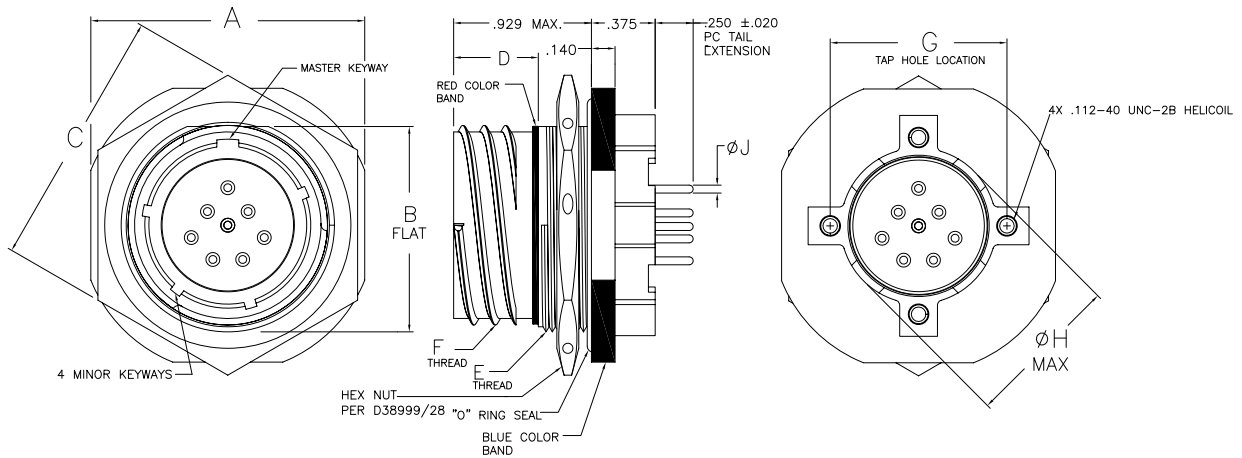

AEP65-105

AEP65-106

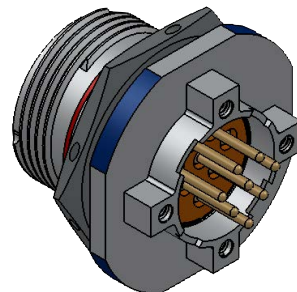
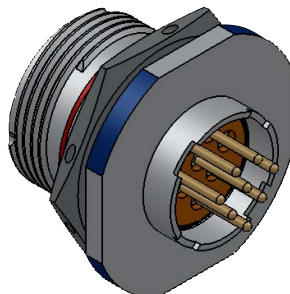

* Standard PC tail extension length. For optional lengths, 229-234 for further information

MIL-DTL-38999 Series III
Rear, Jam Nut Receptacle
AE65-505



Part Number Development

Aero Prefix	AE65-	505-	W	D	19	P	N-	2	4	H	1	3	5-	C1
Shell Type 505 = Box Mount														
Material Finish W = Aluminum, Olive Drab Cadmium Over Nickel F = Aluminum, Olive Drab Cadmium Over Nickel E = Stainless Steel, Passivated (Non-Firewall) BN = Aluminum, Black Nickel (RoHS) BZ = Aluminum, Nickel Bronze (RoHS)														
Shell Size A=9, B=11, C=13, D=15, E=17, F=19, G=21, H=23, J=25														
Insert Arrangement Per MIL-STD-1560. See Pages 194 Thru 208 for Insert Selection.														
Contact Style P = Pin S = Socket														
Polarization (Keying) A, B, C, D & E (N = Normal)														
P.C. Tail Diameter 0=No Size 20 or 22D Contact size 20 & 22D : 1=.019, 2=.025, 3=.030 (with .033 min. stand-off dia. for contact size 22D, with .043 min. stand-off dia. o contact size 20)														
P.C. Tail Extension 1=.140, 2=.200, 3=.250, 4=.300, 5=.080														
Plating K = 30 Microinches Gold H = 50 Microinches Gold														
Stand-Off 0 = No Stand-Off 1 = .040 Stand-Off														
Minimum Solder Dip Length 0 = No Solder Dip, 1 = .100, 2 = .150, 3 = .200, 4 = .250														
P.C.Tail Diameter Blank = No Size 16 Contact size 16: 5=.040, 6=.062 . (with .065 Min. Stand-Off Dia. for contact size 16)														
Clinch Nuts (Self-Clinching) C1 = THD size 4-40 C2 = THD size 6-32 C3 = THD size M3 Blank = No Clinch Nuts														

PCB



**MIL-DTL-38999 Series III
Rear, Jam Nut Receptacle
AE65-505**

AE65-505

SHELL SIZE	MS Shell Code	A TYP ±.012	B TYP	C TYP	D TYP ±.008	E TYP ±.008	F THREAD TRIPLE START	G +.000 - .005	H	ØK MAX	L P.C. TAIL EXTENSION				ØM ±.001 P.C. TAIL DIAMETERS				N ±.010	
											22D, 20 & 16				22D & 20		16			
9	A	.937	.719	.594	.216	.128	.6250-.1P-.3L	.820	.098	.083	.140	.200	.250	.300	.019	.025	.030	.040	.062	.719
11	B	1.031	.812	.719	.194		.7500-.1P-.3L													.812
13	C	1.126	.906	.812	.194		.8750-.1P-.3L													.906
15	D	1.220	.969	.906	.173		1.000-.1P-.3L													.969
17	E	1.311	1.062	.969	.194		1.187-.1P-.3L													1.062
19	F	1.437	1.156	1.062	.194		1.250-.1P-.3L													1.156
21	G	1.563	1.250	1.156	.194	1.375-.1P-.3L	1.250	.126	.083										1.225	
23	H	1.689	1.375	1.250	.242	1.500-.1P-.3L	1.375													
25	J	1.811	1.500	1.375	.242	1.625-.1P-.3L	1.500												1.345	
																			1.460	

AE65-505 Receptacle Connector, Wall Mount with P.C. Contacts with and without Clinch Nuts

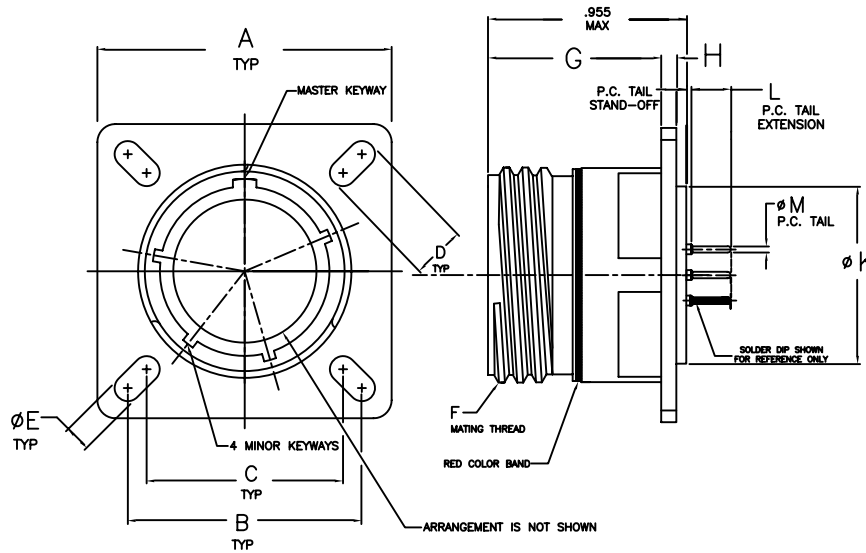

CONNECTOR IS SHOWN LESS CLINCH NUTS

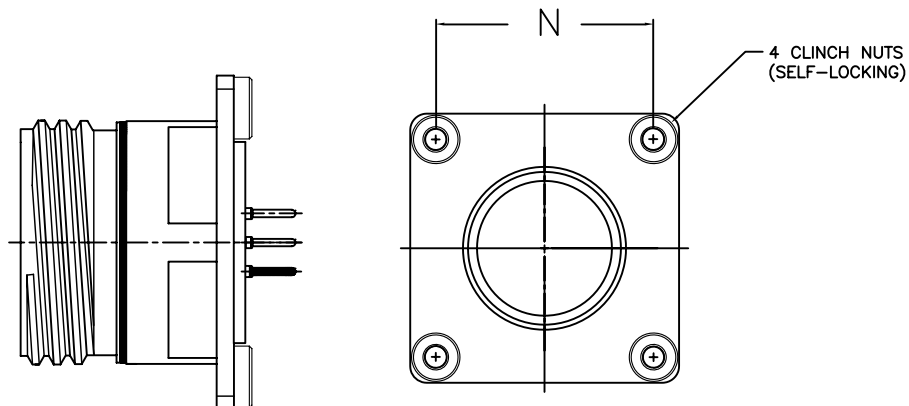

CONNECTOR IS SHOWN WITH CLINCH NUTS & PC CONTACTS

PCB

MIL-DTL-38999 Series III Rear, Jam Nut Receptacle AE65-512



Part Number Development

Aero Prefix	AE65-	512-	W	B	35	P	N	1
Shell Type	512 = Jam Nut							
Material Finish	W = Aluminum, Olive Drab/Cadmium F = Aluminum, Electroless Nickel E = Stainless Steel, Passivated (Non-Firewall) BN = Aluminum, Black Nickel (RoHS) BZ = Aluminum, Nickel Bronze (RoHS)							
Shell Size	A=9, B=11, C=13, D=15, E=17, F=19, G=21, H=23, J=25							
Insert Arrangement	Per MIL-STD-1560. See Pages 194 Thru 208 for Insert Selection.							
Contact Style	P = Pin S = Socket							
Polarization (Keying)	A, B, C, D & E (N = Normal)							
Dash Number	1-"L1" Length P.C. Tail Contact 2-"L2" Length P.C. Tail Contact 3-"L3" Length P.C. Tail Contact 4-"L4" Length P.C. Tail Contact 5-"L5" Length P.C. Tail Contact							

PCB

AE65-512

SHELL SIZE	MS Shell Code	A		B Mtg. Flat		C HEX		D THREAD TRIPLE START	E Thread	F		L1 P.C.TAIL Dash 1		L2 P.C.TAIL Dash 2		L3 P.C.TAIL Dash 3		L4 P.C.TAIL Dash 4		L5 P.C.TAIL Dash 5	
		inch ±.016	MM ±0.040	Inch +.004 -0.006	MM +0.10 -0.15	Inch	MM			inch +.028 -0.004	MM +0.71 -0.10	INCH	MM	INCH	MM	INCH	MM	INCH	MM	INCH	MM
		9	A	1.063	27.00	.651	16.53			.945 .859	24.00 21.82	.6250-.1P-.3L	M17X1.0-6g.100R	.087	2.21						
11	B	1.252	31.80	.751	19.07	1.063 .984	27.00 24.99	.7500-.1P-.3L	M20X1.0-6g.100R	.087	2.21										
13	C	1.374	34.90	.937	23.82	1.259 1.172	32.00 29.77	.8750-.1P-.3L	M25X1.0-6g.100R	.087	2.21										
15	D	1.500	38.10	1.062	26.97	1.417 1.296	36.00 32.91	1.000-.1P-.3L	M28X1.0-6g.100R	.087	2.21										
17	E	1.626	41.30	1.187	30.15	1.457 1.422	37.00 36.12	1.187-.1P-.3L	M32X1.0-6g.100R	.087	2.21	.170 .130	4.32 3.30	.240 .200	6.10 5.08	.320 .280	8.13 7.11	.390 .350	9.91 8.89	.590 .550	14.99 13.97
19	F	1.811	46.00	1.312	33.32	1.614 1.546	41.00 39.27	1.250-.1P-.3L	M35X1.0-6g.100R	.118	3.00										
21	G	1.937	49.20	1.437	36.50	1.811 1.672	46.00 42.47	1.375-.1P-.3L	M38X1.0-6g.100R	.118	3.00										
23	H	2.063	52.40	1.562	39.67	1.969 1.796	50.01 45.62	1.500-.1P-.3L	M41X1.0-6g.100R	.118	3.00										
25	J	2.189	55.60	1.687	42.85	2.017 1.939	51.23 49.25	1.625-.1P-.3L	M44X1.0-6g.100R	.118	3.00										



MIL-DTL-38999 Series III
Rear, Jam Nut Receptacle
AE65-255

PCB

AE65-512 Receptacle Connector, Jam Nut

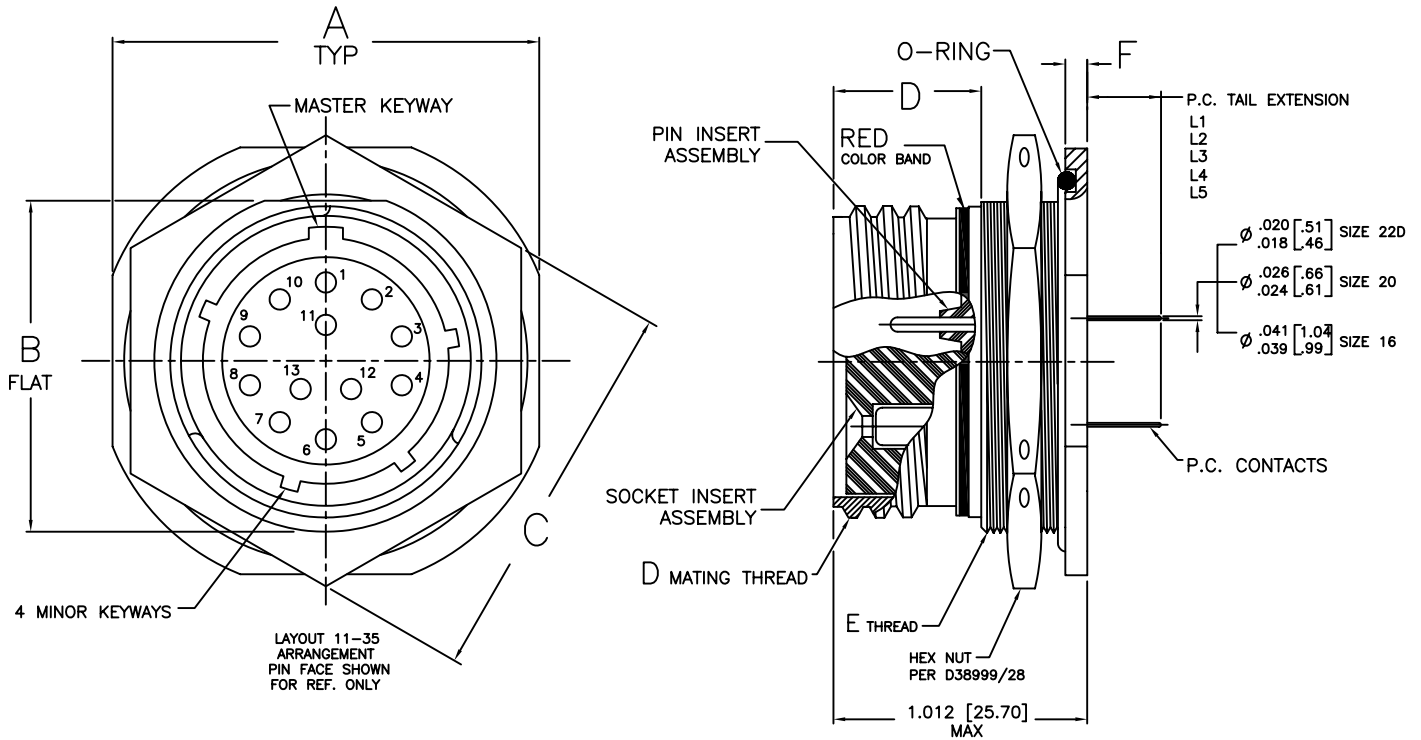

MIL-DTL-38999 Series III Receptacle Connector, Wall Mount AE6520



Part Number Development

Aero Prefix	AE65	20	W	D	19	P	N-	2	4	H	1	3	5-	C1
Shell Type 20 = Wall Mount Receptacle														
Material Finish W = Aluminum, Olive Drab Cadmium Over Nickel F = Aluminum, Olive Drab Cadmium Over Nickel S = Stainless Steel, Electrodeposited Nickel, Firewall K = Stainless Steel, Passivated, Firewall E = Stainless Steel, Passivated (Non-Firewall) BN = Aluminum, Black Nickel (RoHS) BZ = Aluminum, Nickel Bronze (RoHS)														
Shell Size A=9, B=11, C=13, D=15, E=17, F=19, G=21, H=23, J=25														
Insert Arrangement Per MIL-STD-1560. See Pages 194 Thru 208 for Insert Selection.														
Contact Style P = Pin S = Socket														
Polarization (Keying) A, B, C, D & E (N = Normal)														
P.C. Tail Diameter 0=No Size 20 or 22D Contact size 20 & 22D : 1=.019, 2=.025, 3=.030 (with .033 min. stand-off dia. for contact size 22D, with .043 min. stand-off dia. o contact size 20)														
P.C. Tail Extension 1=.140, 2=.200, 3=.250, 4=.300, 5=.080														
Plating K = 30 Microinches Gold H = 50 Microinches Gold														
Stand-Off 0 = No Stand-Off 1 = .040 Stand-Off														
Minimum Solder Dip Length 0 = No Solder Dip, 1 = .100, 2 = .150, 3 = .200, 4 = .250														
P.C.Tail Diameter Blank = No Size 16 Contact size 16: 5=.040, 6=.062. (with .065 Min. Stand-Off Dia. for contact size 16)														
Clinch Nuts (Self-Clinching) C1 = THD size 4-40 C2 = THD size 6-32 C3 = THD size M3 Blank = No Clinch Nuts														

PCB



AE6520

SHELL SIZE	MS Shell Code	A TYP ±.012	B TYP	C TYP	D TYP ±.008	E TYP ±.008	F THREAD TRIPLE START	G +.000 - .005	H	J Max	K Accessory Thread	L P.C. TAIL EXTENSION				ØM ±.001 P.C. TAIL DIAMETERS				
												22D, 20 & 16				22D & 20		16		
												.140	.200	.250	.300	.019	.025	.030	.040	.062
9	A	.937	.719	.594	.216	.128	.6250-.1P-.3L	.820	.098	.493	M12X1.0-6g,100R	.140	.200	.250	.300	.019	.025	.030	.040	.062
11	B	1.031	.812	.719	.194		.7500-.1P-.3L				M15X1.0-6g,100R									
13	C	1.126	.906	.812	.194		.8750-.1P-.3L				M18X1.0-6g,100R									
15	D	1.220	.969	.906	.173		1.000-.1P-.3L				M22X1.0-6g,100R									
17	E	1.311	1.062	.969	.194		1.187-.1P-.3L				M25X1.0-6g,100R									
19	F	1.437	1.156	1.062	.194		1.250-.1P-.3L				M28X1.0-6g,100R									
21	G	1.563	1.250	1.156	.194	1.375-.1P-.3L	.790	.126	.523	M31X1.0-6g,100R	.140	.200	.250	.300	.019	.025	.030	.040	.062	
23	H	1.689	1.375	1.250	.242	1.500-.1P-.3L				M34X1.0-6g,100R										
25	J	1.811	1.500	1.375	.242	1.625-.1P-.3L				M37X1.0-6g,100R										

AE6520 Receptacle Connector, Wall Mount with or without Clinch Nuts

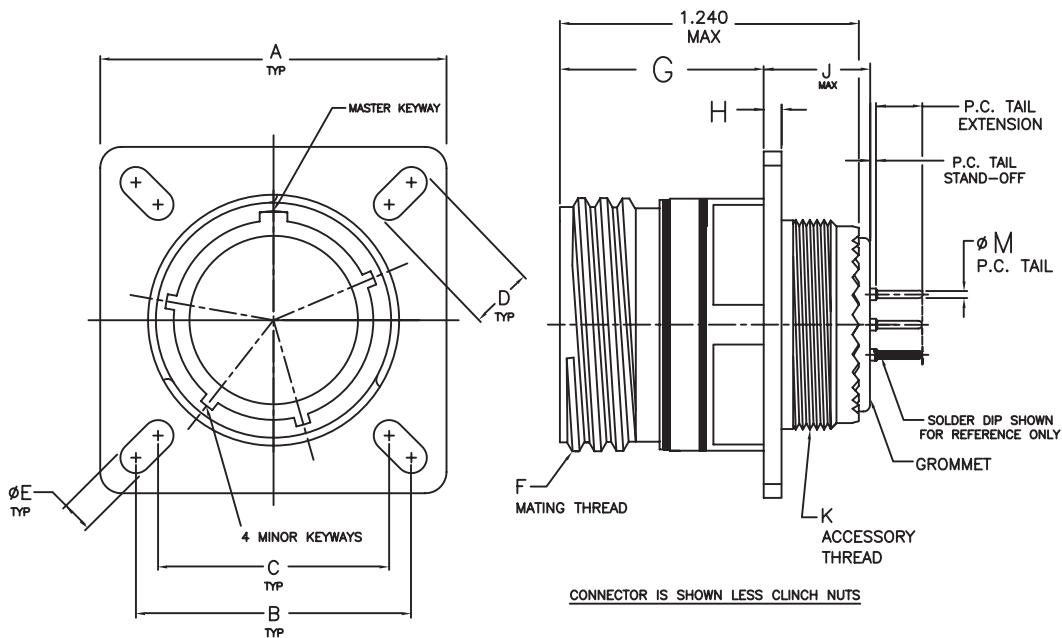

SHELL SIZE	N	
	inch ±.010	MM ±0.26
9	.719	18.26
11	.812	20.62
13	.906	23.01
15	.969	24.61
17	1.062	26.97
19	1.156	29.36
21	1.250	31.75
23	1.375	34.93
25	1.500	38.10

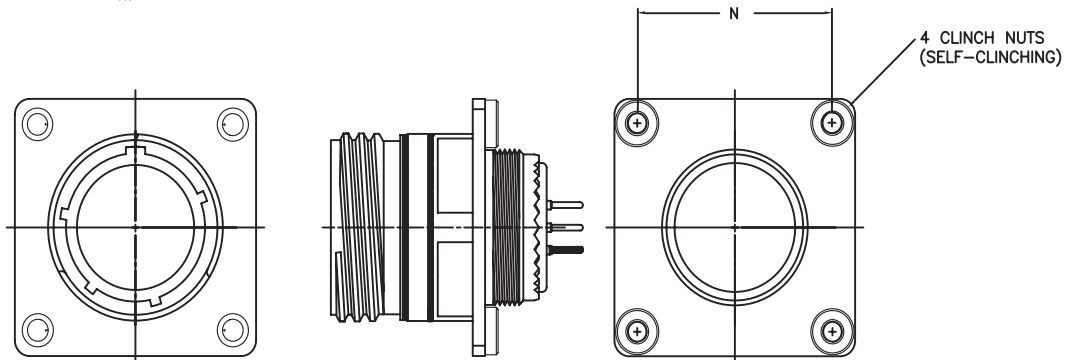

Connector is shown with clinch nuts and PC Contacts

MIL-DTL-38999 Series III Receptacle Connector, Single Hole Mount AE6524



Part Number Development

Aero Prefix	AE65	24	W	D	19	P	N-	2	4	H	1	3	5
Shell Type 24 = Single Hole Mount Receptacle													
Material Finish W = Aluminum, Olive Drab Cadmium Over Nickel F = Aluminum, Olive Drab Cadmium Over Nickel S = Stainless Steel, Electrodeposited Nickel, Firewall K = Stainless Steel, Passivated, Firewall E = Stainless Steel, Passivated (Non-Firewall) BN = Aluminum, Black Nickel (RoHS) BZ = Aluminum, Nickel Bronze (RoHS)													
Shell Size A=9, B=11, C=13, D=15, E=17, F=19, G=21, H=23, J=25													
Insert Arrangement Per MIL-STD-1560. See Pages 194 Thru 208 for Insert Selection.													
Contact Style P = Pin S = Socket													
Polarization (Keying) A, B, C, D & E (N = Normal)													
P.C. Tail Diameter 0=No Size 20 or 22D Contact size 20 & 22D : 1=.019, 2=.025, 3=.030 4=.027 (with .040 min. stand-off dia. for contact size 22D, with .060 min. stand-off dia. o contact size 20) 5 = .019 (.019 with .046 Min stand-off diameter for contact size 22D)													
P.C. Tail Extension 1=.140, 2=.200, 3=.250, 4=.300, 5=.080													
Plating K = 30 Microinches Gold H = 50 Microinches Gold													
Stand-Off 0 = No Stand-Off 1 = .040 Stand-Off													
Minimum Solder Dip Length 0 = No Solder Dip, 1 = .100, 2 = .150, 3 = .200, 4 = .250, 5 = .080													
P.C.Tail Diameter Blank = No Size 16 Contact size 16: 5=.040, 6=.062 . (with .090 Min. Stand-Off Dia. for contact size 16)													

PCB



MIL-DTL-38999 Series III
Receptacle Connector, Single Hole Mount
AE6524

AE6524

SHELL SIZE	MS Shell Code	A TYP ±.016	B MTG. Flat +.004 -.008	C Hex +.017 -.016	E THREAD	F THREAD TRIPLE START	H +.035 -.004	K Accessory Thread	L P.C. TAIL EXTENSION				ØM ±.001 P.C. TAIL DIAMETERS					
									22D, 20 & 16				22D & 20		16			
									.080	.140	.200	.300	.019	.025	.027	.030	.040	.062
9	A	1.063	.651	.875	M17X1.0-6g.100R	.625-.1P-.3L	.087	M12X1.0-6g.100R										
11	B	1.252	.751	1.000	M20X1.0-6g.100R	.750-.1P-.3L		M15X1.0-6g.100R										
13	C	1.374	.937	1.188	M25X1.0-6g.100R	.875-.1P-.3L		M18X1.0-6g.100R										
15	D	1.500	1.062	1.312	M28X1.0-6g.100R	1.000-.1P-.3L		M22X1.0-6g.100R										
17	E	1.626	1.187	1.438	M32X1.0-6g.100R	1.187-.1P-.3L	M25X1.0-6g.100R											
19	F	1.811	1.312	1.562	M35X1.0-6g.100R	1.250-.1P-.3L	M28X1.0-6g.100R											
21	G	1.937	1.437	1.688	M38X1.0-6g.100R	1.375-.1P-.3L	M31X1.0-6g.100R											
23	H	2.063	1.562	1.812	M41X1.0-6g.100R	1.500-.1P-.3L	M34X1.0-6g.100R											
25	J	2.189	1.687	2.000	M44X1.0-6g.100R	1.625-.1P-.3L	M37X1.0-6g.100R											

AE6524 Receptacle Connector, Single Hole Mount

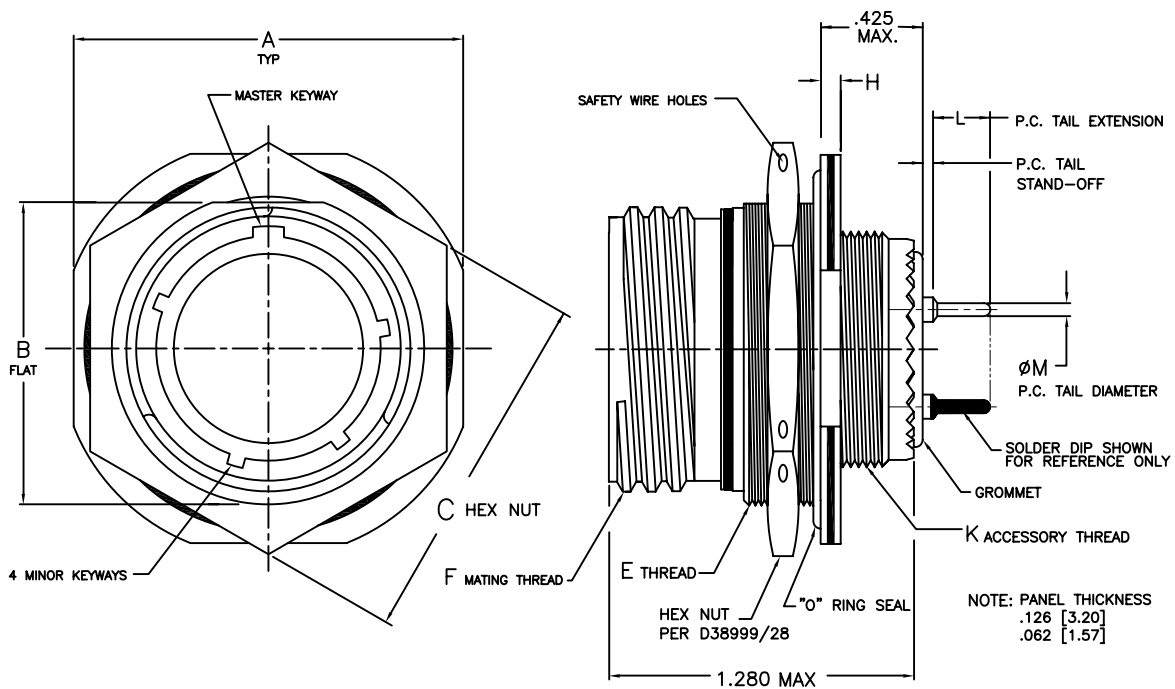

PCB

MIL-DTL-38999 Series I Rear, Wall Mount Receptacle AEP45-101, AEP45-102



Part Number Configuration

Aero Prefix	AEP45-	101-	F	21	35	P	A-	***
Shell Type	<p>101 = Rear Wall Mount 102 = Rear Wall Mount w/ Clinch Nuts</p>							
Material Finish	<p>F = Aluminum, Electroless Nickel B = Aluminum, Olive Drab Cadmium Over Nickel BN = Aluminum, Black Nickel, (RoHS) T = Aluminum, Teflon Nickel, (RoHS), (consult factory for availability) Z = Aluminum, Black Zinc Nickel, (RoHS), (consult factory for availability)</p>							
Shell Size	<p>9, 11, 13, 15, 17, 19, 21, 23, 25</p>							
Insert Arrangement	<p>Per MIL-STD-1560. See Pages 194-208 for Insert Selection.</p>							
Contact Style	<p>P = Pin S = Socket</p>							
Polarization (Keying)	<p>A, B, C, or D (Blank = Normal)</p>							
Options (Aero Modification Number)	<p>***Consult factory for other modifications</p>							

AEP45-101 and -102 Dimensional Data

SHELL SIZE	A ±.020	B	ØC +.010 -.005 (AEP45-101)	ØE +.001 -.005	ØF MAX.
09	.938	.719	.128	.572	.460
11	1.031	.812	.128	.700	.586
13	1.125	.906	.128	.850	.710
15	1.219	.969	.128	.975	.834
17	1.312	1.062	.128	1.100	.960
19	1.438	1.156	.128	1.207	1.070
21	1.562	1.250	.128	1.332	1.186
23	1.688	1.375	.147	1.457	1.320
25	1.812	1.500	.147	1.582	1.446

Standard PC Tail Diameters

CONTACT SIZE	ØG ±.001
22D	.019
20	.019
16	.062

Alternate PC Tail diameters and lengths are available. Refer to PC Tail Specification section starting on 229-234 for further information, or consult Conesys/Aero Electric Connector for application support.

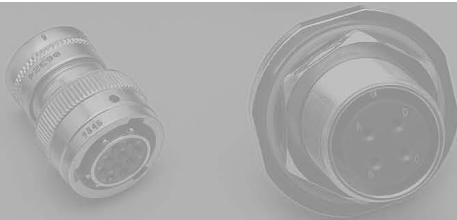

MIL-DTL-38999 Series I
Rear, Wall Mount Receptacle
AEP45-101, AEP45-102

AEP45-101 Receptacle Connector, Rear Wall Mount

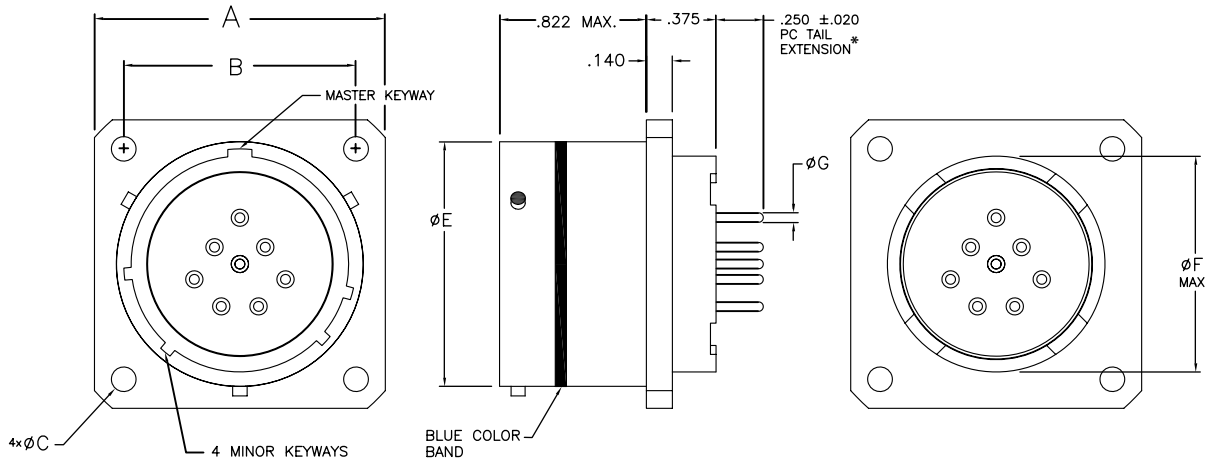

AEP45-102 Receptacle Connector, Rear Wall Mount with Clinch Nuts

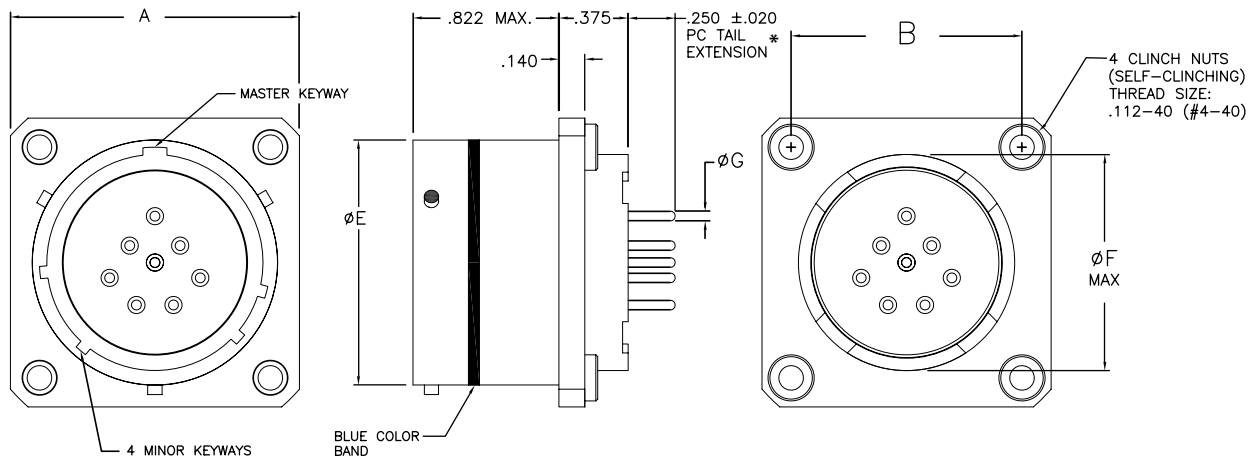

AEP45-101

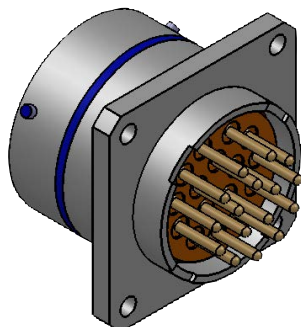

AEP45-102

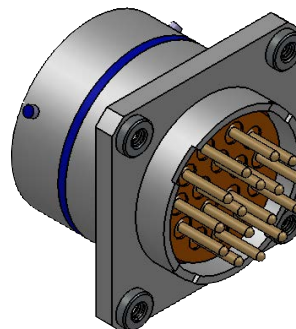

* Standard PC tail extension length. For optional lengths, 229-234 for further information

MIL-DTL-38999 Series I
Rear, Wall Mount Receptacle, Dual Flange
AEP45-103, AEP45-104



Part Number Development

Aero Prefix	AEP45-	103-	F	21	35	P	A-	***
Shell Type	<p>103 = Rear Wall Mount w/ Dual Flange 104 = Rear Wall Mount w/ Dual Flange & Clinch Nuts</p>							
Material Finish	<p>F = Aluminum, Electroless Nickel B = Aluminum, Olive Drab Cadmium Over Nickel BN = Aluminum, Black Nickel, (RoHS) T = Aluminum, Teflon Nickel, (RoHS), (consult factory for availability) Z = Aluminum, Black Zinc Nickel, (RoHS), (consult factory for availability)</p>							
Shell Size	<p>9, 11, 13, 15, 17, 19, 21, 23, 25</p>							
Insert Arrangement	<p>Per MIL-STD-1560. See Pages 194 Thru 208 for Insert Selection.</p>							
Contact Style	<p>P = Pin S = Socket</p>							
Polarization (Keying)	<p>A, B, C, or D (Blank = Normal)</p>							
Options (Aero Modification Number)	<p>***Consult factory for other modifications</p>							

AEP45-103 and -104 Dimensional Data

SHELL SIZE	A ±.020	B	ØC +.010 -.005 (AEP45-103)	ØE +.001 -.005	ØF MAX.	G
09	.938	.719	.128	.572	.460	.556
11	1.031	.812	.128	.700	.586	.686
13	1.125	.906	.128	.850	.710	.802
15	1.219	.969	.128	.975	.834	.927
17	1.312	1.062	.128	1.100	.960	1.048
19	1.438	1.156	.128	1.207	1.070	1.126
21	1.562	1.250	.128	1.332	1.186	1.250
23	1.688	1.375	.147	1.457	1.320	1.387
25	1.812	1.500	.147	1.582	1.446	1.500

Standard PC Tail Diameters

CONTACT SIZE	ØH ±.001
22D	.019
20	.019
16	.062

Alternate PC Tail diameters and lengths are available. Refer to PC Tail Specification section starting on 229-234 for further information, or consult Conesys/Aero Electric Connector for application support.



MIL-DTL-38999 Series I
Rear, Wall Mount Receptacle, Dual Flange
AEP45-103, AEP45-104

AEP45-103 Receptacle Connector, Rear Wall Mount with Dual Flange

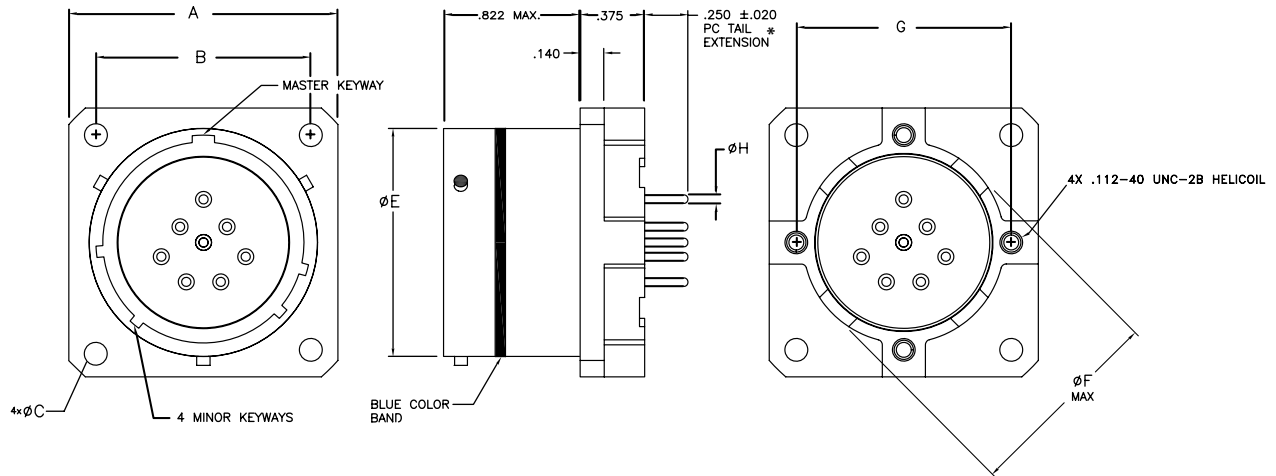

AEP45-104 Receptacle Connector, Rear Wall Mount with Dual Flange and Clinch Nuts

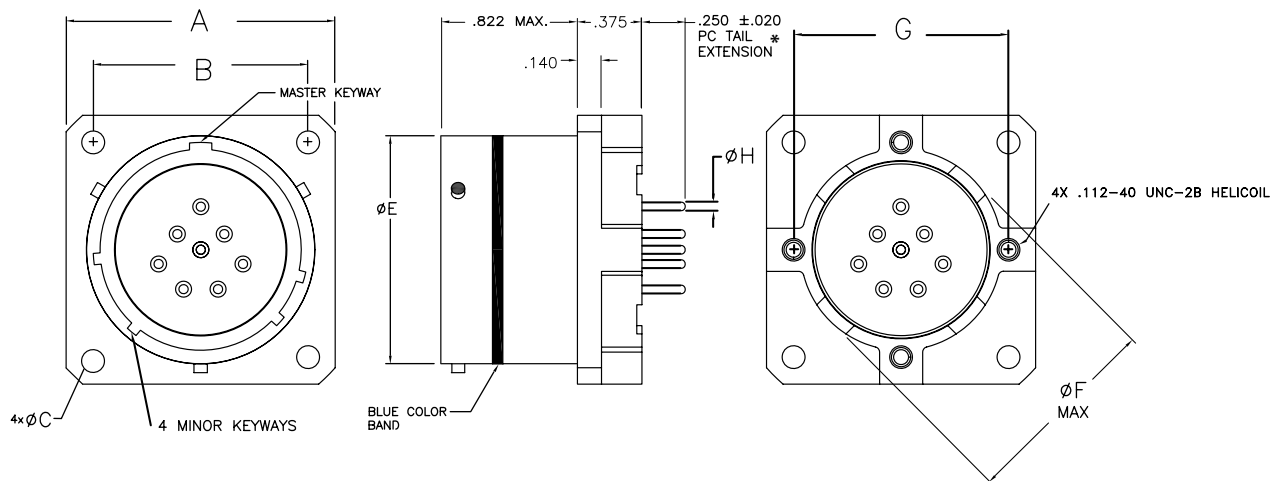

AEP45-103

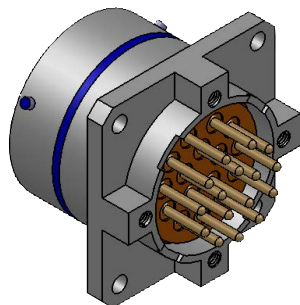

AEP45-104

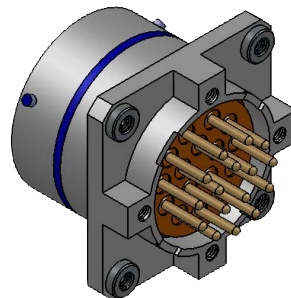

* Standard PC tail extension length. For optional lengths, 229-234 for further information

MIL-DTL-38999 Series I Jam Nut Receptacle AEP45-105, AEP45-106



Part Number Development

Aero Prefix	AEP45-	105-	F	21	35	P	A-	***
Shell Type	<p>105 = Jam Nut Mount 106 = Jam Nut Mount w/ Dual Flange</p>							
Material Finish	<p>F = Aluminum, Electroless Nickel B = Aluminum, Olive Drab Cadmium Over Nickel BN = Aluminum, Black Nickel, (RoHS) T = Aluminum, Teflon Nickel, (RoHS), (consult factory for availability) Z = Aluminum, Black Zinc Nickel, (RoHS), (consult factory for availability)</p>							
Shell Size	<p>9, 11, 13, 15, 17, 19, 21, 23, 25</p>							
Insert Arrangement	<p>Per MIL-STD-1560. See Pages 194 Thru 208 for Insert Selection.</p>							
Contact Style	<p>P = Pin S = Socket</p>							
Polarization (Keying)	<p>A, B, C, or D (Blank = Normal)</p>							
Options (Aero Modification Number)	<p>***Consult factory for other modifications</p>							

AEP45-105 and -106 Dimensional Data

SHELL SIZE	A ±.016	B	ØC ±.016	D THREAD	ØE +.001 -.005	ØF MAX	G (AEP45-106)
8	1.062	.650	1.188	11/16-24 UNEF	.572	.460	.556
10	1.250	.750	1.375	13/16-20 UNEF	.700	.586	.686
12	1.375	.937	1.500	1-20 UNEF	.850	.710	.802
14	1.500	1.061	1.625	1 1/8-18 UNEF	.975	.834	.927
16	1.625	1.186	1.750	1 1/4-18 UNEF	1.100	.960	1.048
18	1.812	1.311	1.938	1 3/8-18 UNEF	1.207	1.070	1.126
20	1.938	1.436	2.062	1 1/2-18 UNEF	1.332	1.186	1.250
22	2.062	1.561	2.188	1 5/8-18 UNEF	1.457	1.320	1.387
24	2.188	1.686	2.312	1 3/4-18 UNS	1.582	1.446	1.500

Standard PC Tail Diameters

CONTACT SIZE	ØG ±.001
22D	.019
20	.019
16	.062

Alternate PC Tail diameters and lengths are available. Refer to PC Tail Specification section starting on 229-234 for further information, or consult Conesys/Aero Electric Connector for application support.

AEP45-105 Receptacle Connector, Jam Nut Mount

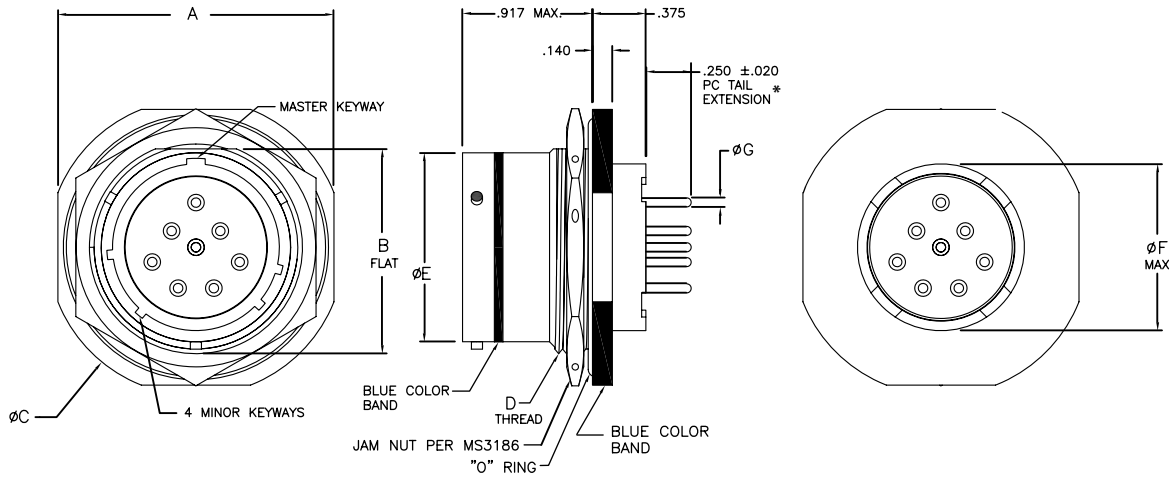

AEP45-106 Receptacle Connector, Jam Nut Mount with Dual Flange

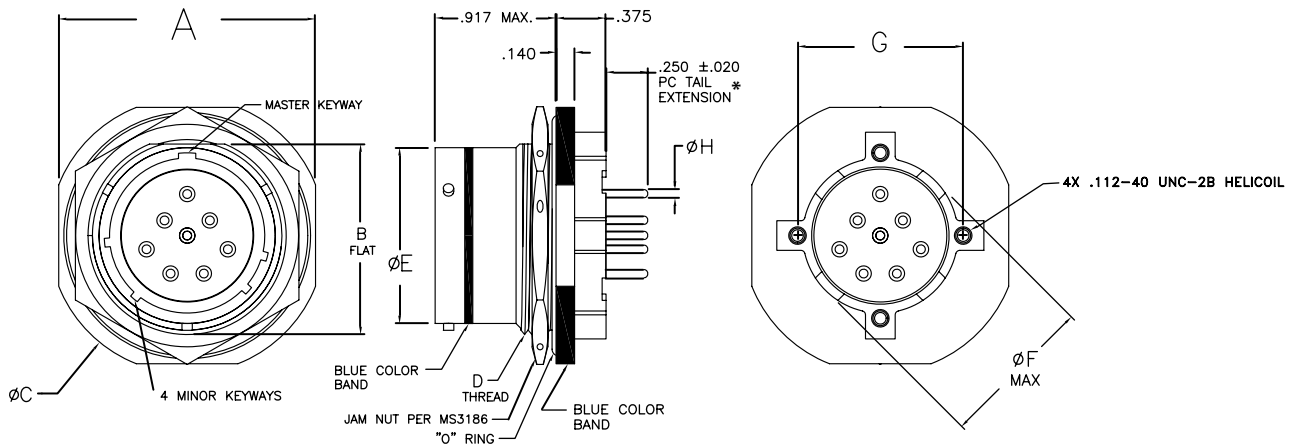

AEP45-105

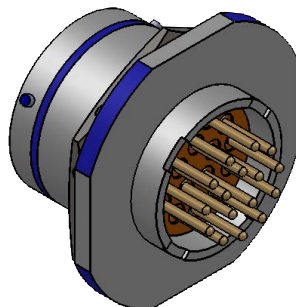

AEP45-106

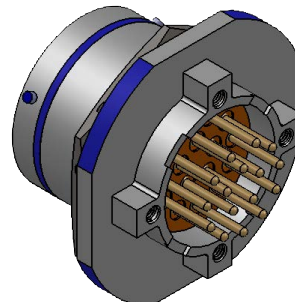

* Standard PC tail extension length. For optional lengths, 229-234 for further information

MIL-DTL-38999 Series II Rear, Wall Mounting Receptacle AEP55-101, AEP55-102



Part Number Development

Aero Prefix	AEP55-	101-	F	20	35	P	A-	***
Shell Type								
101 = Rear Wall Mount								
102 = Rear Wall Mount w/ Clinch Nuts								
Material Finish								
F = Aluminum, Electroless Nickel								
B = Aluminum, Olive Drab Cadmium Over Nickel								
BN = Aluminum, Black Nickel, (RoHS)								
T = Aluminum, Teflon Nickel, (RoHS), (consult factory for availability)								
Z = Aluminum, Black Zinc Nickel, (RoHS), (consult factory for availability)								
Shell Size								
8, 10, 12, 14, 16, 18, 20, 22, 24								
Insert Arrangement								
Per MIL-STD-1560. See Pages 194 Thru 208 for Insert Selection.								
Contact Style								
P = Pin								
S = Socket								
Polarization (Keying)								
A, B, C, or D (Blank = Normal)								
Options (Aero Modification Number)								
***Consult factory for other modifications								

AEP55-101 and -102 Dimensional Data

SHELL SIZE	A MAX	B	ØC	ØD MAX	ØE ±.003
			+0.010 -0.005 (AEP55-101)		
8	.828	.594	.120	.460	.471
10	.954	.719	.120	.586	.588
12	1.047	.812	.120	.710	.748
14	1.141	.906	.120	.834	.873
16	1.234	.969	.120	.960	.998
18	1.328	1.062	.120	1.070	1.123
20	1.453	1.156	.120	1.186	1.248
22	1.578	1.250	.120	1.320	1.373
24	1.703	1.375	.147	1.446	1.498

Standard PC Tail Diameters

CONTACT SIZE	ØF ±.001
22D	.019
20	.019
16	.062

Alternate PC Tail diameters and lengths are available. Refer to PC Tail Specification section starting on 229-234 for further information, or consult Conesys/Aero Electric Connector for application support.



MIL-DTL-38999 Series II
Rear, Wall Mount Receptacle
AEP55-101, AEP55-102

AEP55-101 Receptacle Connector, Rear Wall Mount

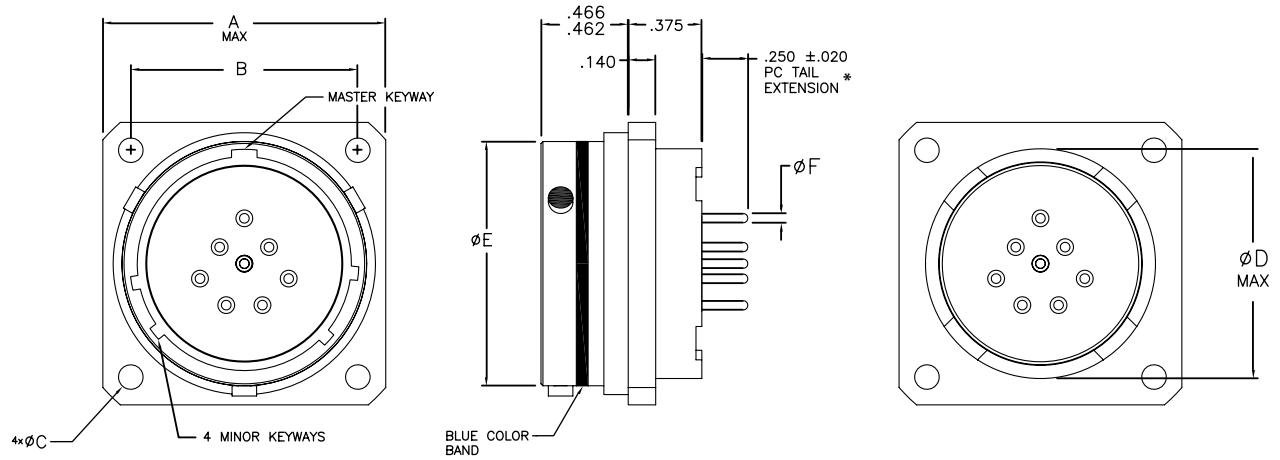

AEP55-102 Receptacle Connector, Rear Wall Mount with Clinch Nuts

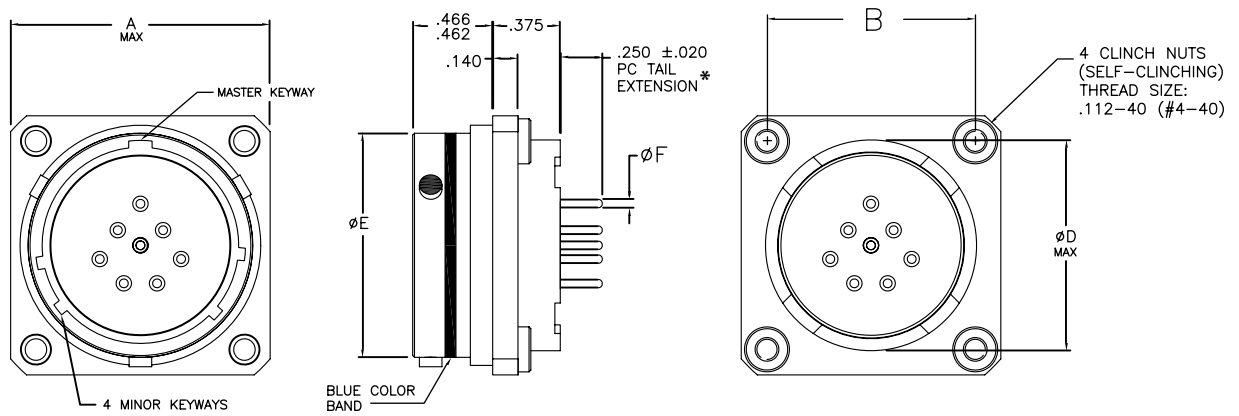

AEP55-101

AEP55-102

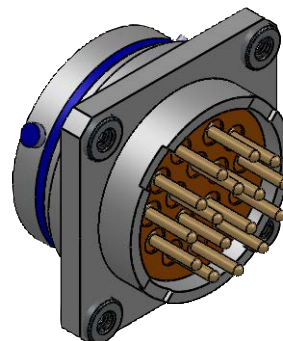
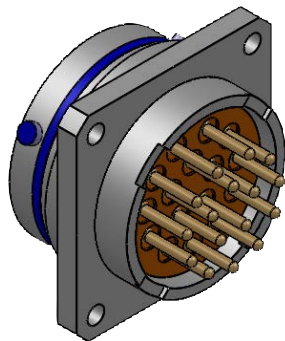

* Standard PC tail extension length. For optional lengths, 229-234 for further information

MIL-DTL-38999 Series II Rear, Wall Mounting Receptacle AEP55-103, AEP55-104



Part Number Development

Aero Prefix	AEP55-	103-	F	20	35	P	A-	***
Shell Type	<p>103 = Rear Wall Mount w/ Dual Flange 104 = Rear Wall Mount w/ Dual Flange & Clinch Nuts</p>							
Material Finish	<p>F = Aluminum, Electroless Nickel B = Aluminum, Olive Drab Cadmium Over Nickel BN = Aluminum, Black Nickel, (RoHS) T = Aluminum, Teflon Nickel, (RoHS), (consult factory for availability) Z = Aluminum, Black Zinc Nickel, (RoHS), (consult factory for availability)</p>							
Shell Size	<p>8, 10, 12, 14, 16, 18, 20, 22, 24</p>							
Insert Arrangement	<p>Per MIL-STD-1560. See Pages 194 Thru 208 for Insert Selection.</p>							
Contact Style	<p>P = Pin S = Socket</p>							
Polarization (Keying)	<p>A, B, C, or D (Blank = Normal)</p>							
Options (Aero Modification Number)	<p>***Consult factory for other modifications</p>							

AEP55-103 and -104 Dimensional Data

SHELL SIZE	A MAX	B	ØC +.010 -.005	ØD MAX	ØE ±.003	F
8	.828	.594	.120	.460	.471	.556
10	.954	.719	.120	.586	.588	.686
12	1.047	.812	.120	.710	.748	.802
14	1.141	.906	.120	.834	.873	.927
16	1.234	.969	.120	.960	.998	1.048
18	1.328	1.062	.120	1.070	1.123	1.126
20	1.453	1.156	.120	1.186	1.248	1.250
22	1.578	1.250	.120	1.320	1.373	1.387
24	1.703	1.375	.147	1.446	1.498	1.500

Standard PC Tail Diameters

CONTACT SIZE	ØG ±.001
22D	.019
20	.019
16	.062

Alternate PC Tail diameters and lengths are available. Refer to PC Tail Specification section starting on 229-234 for further information, or consult Conesys/Aero Electric Connector for application support.

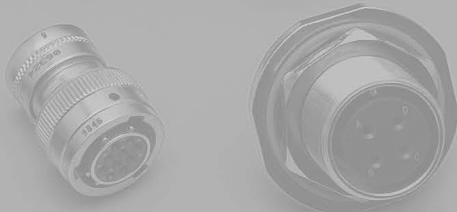

MIL-DTL-38999 Series II
Rear, Wall Mount Receptacle
AEP55-103, AEP55-104

AEP55-103 Receptacle Connector, Rear Wall Mount with Dual Flange

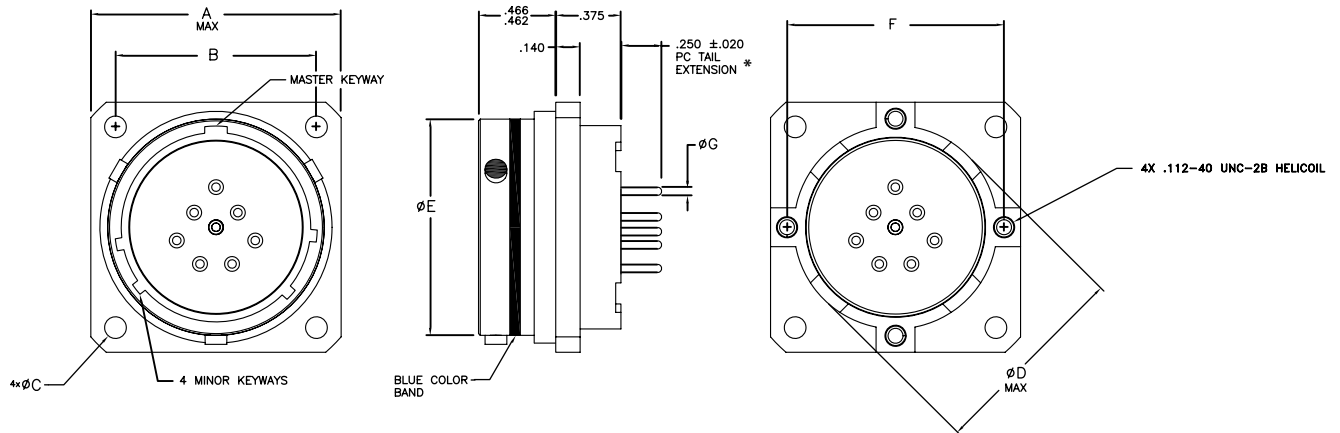

AEP55-104 Receptacle Connector, Rear Wall Mount with Dual Flange and Clinch Nuts

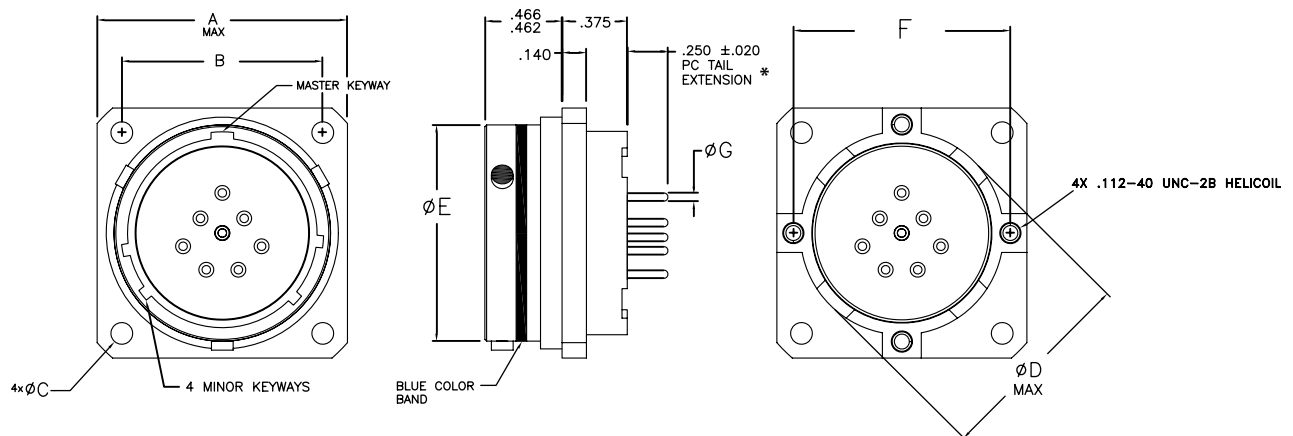

AEP55-103

AEP55-104

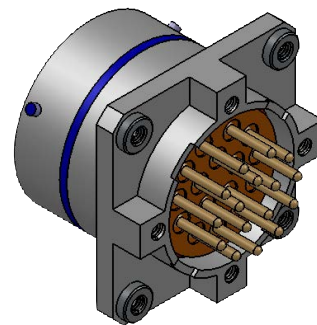
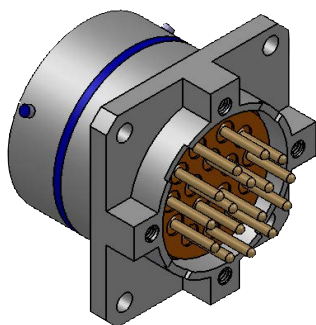

* Standard PC tail extension length. For optional lengths, 229-234 for further information

MIL-DTL-38999 Series II
Rear, Jam Nut Receptacle
AEP55-105, AEP55-106



Part Number Development

Aero Prefix	AEP55-	105-	F	20	35	P	A-	***
Shell Type								
105 = Jam nut Mount								
106 = Jam Nut Mount w/ Dual Flange								
Material Finish								
F = Aluminum, Electroless Nickel								
B = Aluminum, Olive Drab Cadmium Over Nickel								
BN = Aluminum, Black Nickel, (RoHS)								
T = Aluminum, Teflon Nickel (consult factory for availability)								
Z = Aluminum, Black Zinc Nickel, (RoHS), (consult factory for availability)								
Shell Size								
8, 10, 12, 14, 16, 18, 20, 22, 24								
Insert Arrangement								
Per MIL-STD-1560. See Pages 194 Thru 208 for Insert Selection.								
Contact Style								
P = Pin								
S = Socket								
Polarization (Keying)								
A, B, C, or D (Blank = Normal)								
Options (Aero Modification Number)								
***Consult factory for other modifications								

AEP55-105 and -106 Dimensional Data

SHELL SIZE	A ±.016	B +.001 -.006	ØC ±.016	ØE ±.003	ØF MAX	G THREAD	H (AEP55-106)
8	1.250	.817	1.375	.471	.460	.875-20 UNEF	.556
10	1.375	.941	1.500	.588	.586	1.000-20 UNEF	.686
12	1.500	1.065	1.625	.748	.710	1.125-18 UNEF	.802
14	1.625	1.190	1.750	.873	.834	1.250-18 UNEF	.927
16	1.781	1.320	1.938	.998	.960	1.375-18 UNEF	1.048
18	1.890	1.440	2.016	1.123	1.070	1.500-18 UNEF	1.126
20	2.016	1.565	2.141	1.248	1.186	1.625-18 UNEF	1.250
22	2.140	1.690	2.265	1.373	1.320	1.750-18 UNS	1.387
24	2.265	1.815	2.390	1.498	1.446	1.875-16 UN	1.500

Standard PC Tail Diameters

CONTACT SIZE	ØH ±.001
22D	.019
20	.019
16	.062

Alternate PC Tail diameters and lengths are available. Refer to PC Tail Specification section starting on 229-234 for further information, or consult Conesys/Aero Electric Connector for application support.

AEP55-105 Receptacle Connector, Jam Nut Mount

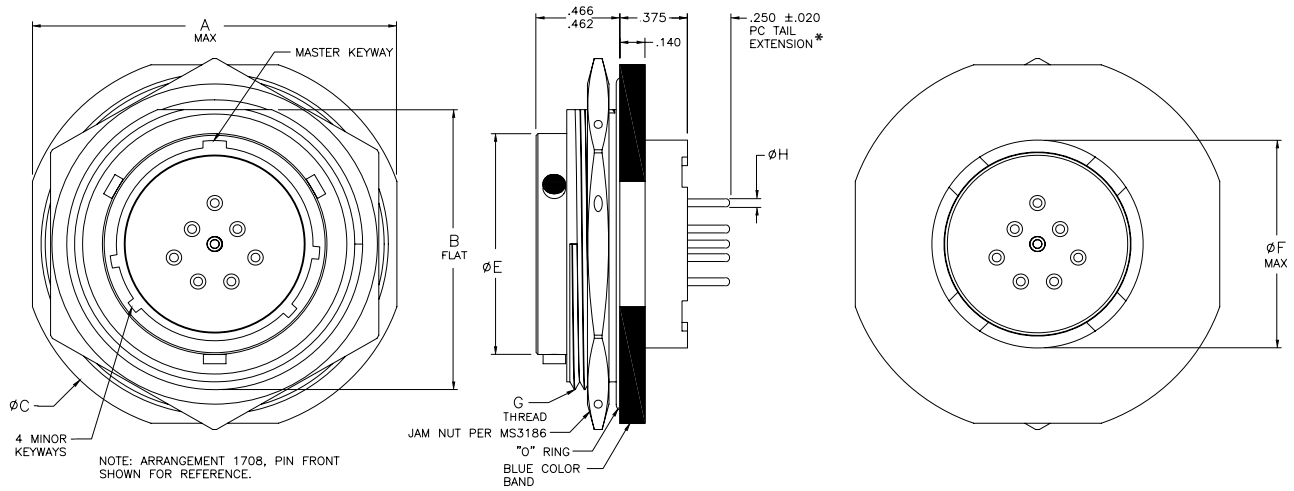

AEP55-106 Receptacle Connector, Jam Nut Mount with Dual Flange

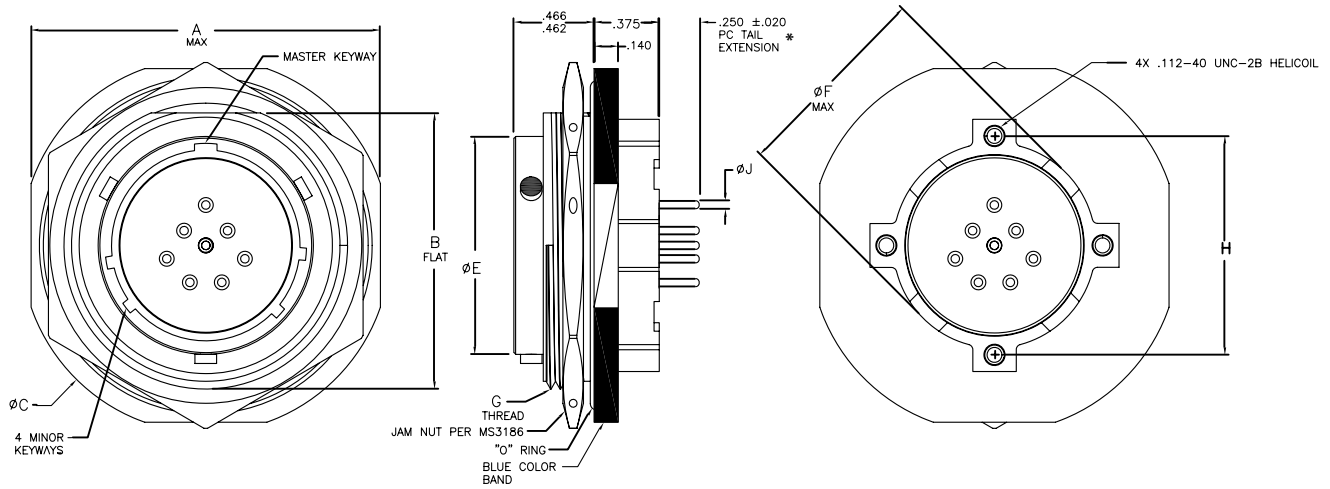

AEP55-105

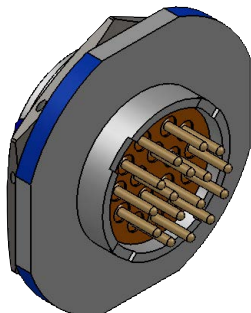

AEP55-106

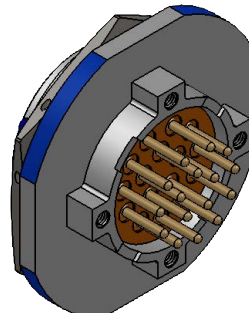

* Standard PC tail extension length. For optional lengths, 229-234 for further information

Circular Connectors - PCB Contacts
MIL-DTL-38999 Series I, II and III
Insert Arrangements - Per MIL-STD-1560



The following table lists the most commonly used insert arrangements for printed circuit board applications using MIL-DTL-38999 circular connectors. Specific dimensional illustrations are included on the following pages for each of the insert arrangements in the table. For availability of other insert arrangements or for application support, please consult Conesys/Aero Electric Connector.

MIL-DTL-38999			Service Rating	Total Contacts	Contact Size		
Series I	Series II	Series III			22D	20	16
9-35	8-35	A35	M	6	6		
9-98	8-98	A98	I	3		3	
11-5	10-5	B5	I	5		5	
11-35	10-35	B35	M	13	13		
11-98	10-98	B98	I	6		6	
13-4	12-4	C4	I	4			4
13-35	12-35	C35	M	22	22		
13-98	12-98	C98	I	10		10	
15-18	14-18	D18	I	18		18	
15-19	-	D19	I	19		19	
15-35	14-35	D35	M	37	37		
17-8	16-8	E8	II	8			8
17-26	16-26	E26	I	26		26	
17-35	16-35	E35	M	55	55		
19-11	18-11	F11	II	11			11
19-32	18-32	F32	I	32		32	
19-35	18-35	F35	M	66	66		
21-35	20-35	G35	M	79	79		
21-41	20-41	G41	I	41		41	
23-35	22-35	H35	M	100	100		
23-55	22-55	H55	I	55		55	
25-29	24-29	J29	I	29			29
25-35	24-35	J35	M	128	128		
25-61	24-61	J61	I	61		61	

*For information on size 12 or larger PC Tail contacts, please consult Conesys/Aero-Electric Connector.

Service Rating	Suggested Operating Voltage**		Test Voltage	Test Voltage	Test Voltage	Test Voltage
	(Sea Level)		Sea Level	50,000 Ft.	70,000 Ft.	100,000 Ft.
	AC (RMS)	DC	V RMS	V RMS	V RMS	V RMS
M	400	550	1300	550	350	200
N	300	450	1000	400	260	200
I	600	850	1800	600	400	200
II	900	1250	2300	800	500	200

** To be used by designer only as a guide.



Circular Connectors - PCB Contacts
MIL-DTL-38999 Series I, II and III
Insert Arrangements - Per MIL-STD-1560

Connector Type	MIL-DTL-38999 Series I	MIL-DTL-38999 Series II	MIL-DTL-38999 Series III	Number of Contacts	Contact Size	Service Rating
Insert Designation	9-35	8-35	A35	6	22D	M

Front face of pin insert shown

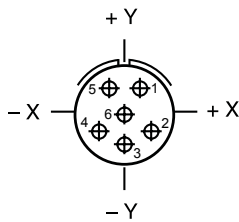

Contact Locations		
Contact Position	Location	
	X-Axis	Y-Axis
1	+0.045	+0.078
2	+0.078	-0.045
3	+0.000	-0.090
4	-0.078	-0.045
5	-0.045	+0.078
6	+0.000	+0.000

Connector Type	MIL-DTL-38999 Series I	MIL-DTL-38999 Series II	MIL-DTL-38999 Series III	Number of Contacts	Contact Size	Service Rating
Insert Designation	9-98	8-98	A98	3	20	I

Front face of pin insert shown

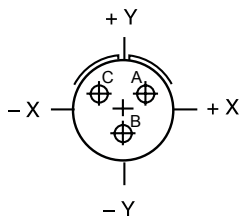

Contact Locations		
Contact Position	Location	
	X-Axis	Y-Axis
A	+0.065	+0.038
B	+0.000	-0.075
C	-0.065	+0.038

Alternate PC Tail diameters are available. Refer to PC Tail Specification section starting on 229-234. Dimensional data for the most common insert patterns for the PCB applications are shown. For availability of other insert arrangements, please consult Conesys/Aero-Electric Connector.

Circular Connectors - PCB Contacts

MIL-DTL-38999 Series I, II and III

Insert Arrangements



Connector Type	MIL-DTL-38999 Series I	MIL-DTL-38999 Series II	MIL-DTL-38999 Series III	Number of Contacts	Contact Size	Service Rating
Insert Designation	11-5	10-5	B5	5	20	I

Front face of pin insert shown

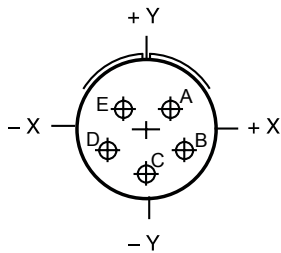

Contact Locations		
Contact Position	Location	
	X-Axis	Y-Axis
A	+0.065	+0.056
B	+0.113	-0.065
C	+0.000	-0.130
D	-0.113	-0.065
E	-0.065	+0.056

Connector Type	MIL-DTL-38999 Series I	MIL-DTL-38999 Series II	MIL-DTL-38999 Series III	Number of Contacts	Contact Size	Service Rating
Insert Designation	11-35	10-35	B35	13	22D	I

Front face of pin insert shown

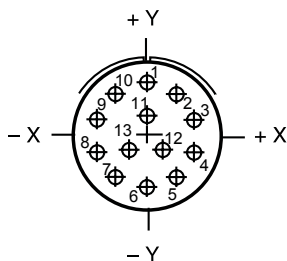

Contact Locations		
Contact Position	Location	
	X-Axis	Y-Axis
1	+0.000	+0.146
2	+0.085	+0.118
3	+0.138	+0.045
4	+0.138	-0.045
5	+0.085	-0.118
6	+0.000	-0.146
7	-0.085	-0.118
8	-0.138	-0.138
9	-0.138	-0.138
10	-0.085	-0.085
11	+0.000	+0.000
12	+0.049	+0.049
13	-0.049	-0.049

Alternate PC Tail diameters are available. Refer to PC Tail Specification section starting on 229-234. Dimensional data for the most common insert patterns for the PCB applications are shown. For availability of other insert arrangements, please consult Conesys/Aero-Electric Connector.



Circular Connectors - PCB Contacts MIL-DTL-38999 Series I, II and III Insert Arrangements

Connector Type	MIL-DTL-38999 Series I	MIL-DTL-38999 Series II	MIL-DTL-38999 Series III	Number of Contacts	Contact Size	Service Rating
Insert Designation	11-98	10-98	B98	6	20	I

Front face of pin insert shown

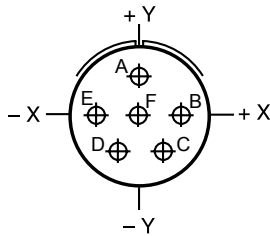

Contact Locations		
Contact Position	Location	
	X-Axis	Y-Axis
A	+0.000	+0.130
B	+0.130	+0.000
C	+0.065	-0.113
D	-0.065	-0.113
E	-0.130	+0.000
F	+0.000	+0.000

Connector Type	MIL-DTL-38999 Series I	MIL-DTL-38999 Series II	MIL-DTL-38999 Series III	Number of Contacts	Contact Size	Service Rating
Insert Designation	13-4	12-4	C4	4	16	I

Front face of pin insert shown

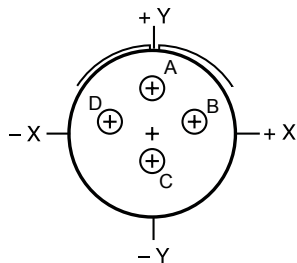

Contact Locations		
Contact Position	Location	
	X-Axis	Y-Axis
A	+0.000	+0.150
B	+0.146	+0.035
C	+0.000	-0.083
D	-0.146	+0.035

Alternate PC Tail diameters are available. Refer to PC Tail Specification section starting on 229-234. Dimensional data for the most common insert patterns for the PCB applications are shown. For availability of other insert arrangements, please consult Conesys/Aero-Electric Connector.

Circular Connectors - PCB Contacts

MIL-DTL-38999 Series I, II and III

Insert Arrangements



Connector Type	MIL-DTL-38999 Series I	MIL-DTL-38999 Series II	MIL-DTL-38999 Series III	Number of Contacts	Contact Size	Service Rating
Insert Designation	13-35	12-35	C35	22	22D	M

Front face of pin insert shown

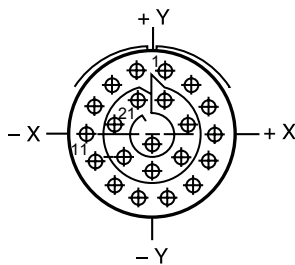

Contact Locations		
Contact Position	Location	
	X-Axis	Y-Axis
1	+045	+197
2	+126	+158
3	+182	+088
4	+203	+000
5	+182	-088
6	+126	-158
7	+045	-197
8	-045	-197
9	-126	-158
10	-182	-088
11	-203	+000

Contact Locations		
Contact Position	Location	
	X-Axis	Y-Axis
12	-182	+088
13	-126	+158
14	-045	+197
15	+045	+107
16	+117	+026
17	+093	-075
18	+000	-120
19	-093	-075
20	-117	+026
21	-045	+107
22	+000	-030

Connector Type	MIL-DTL-38999 Series I	MIL-DTL-38999 Series II	MIL-DTL-38999 Series III	Number of Contacts	Contact Size	Service Rating
Insert Designation	13-98	12-98	C98	10	20	I

Front face of pin insert shown

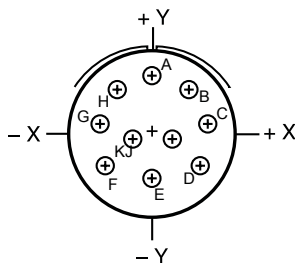

Contact Locations		
Contact Position	Location	
	X-Axis	Y-Axis
A	+000	+195
B	+125	+150
C	+193	+030
D	+164	-105
E	+000	-135
F	-164	-105
G	-193	+030
H	-125	+150
J	+065	-015
K	-065	-015

Alternate PC Tail diameters are available. Refer to PC Tail Specification section starting on 229-234. Dimensional data for the most common insert patterns for the PCB applications are shown. For availability of other insert arrangements, please consult Conesys/Aero-Electric Connector.



Circular Connectors - PCB Contacts MIL-DTL-38999 Series I, II and III Insert Arrangements

Connector Type	MIL-DTL-38999 Series I	MIL-DTL-38999 Series II	MIL-DTL-38999 Series III	Number of Contacts	Contact Size	Service Rating
Insert Designation	15-18	14-18	D18	18	20	I

Front face of pin insert shown

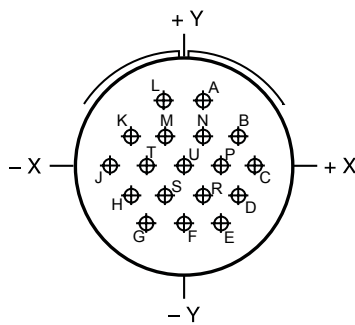

Contact Locations		
Contact Position	Location	
	X-Axis	Y-Axis
A	+0.065	+0.252
B	+0.195	+0.113
C	+0.260	+0.000
D	+0.195	-0.113
E	+0.130	-0.225
F	+0.000	-0.225
G	-0.130	-0.225
H	-0.195	-0.113
J	-0.260	+0.000

Contact Locations		
Contact Position	Location	
	X-Axis	Y-Axis
K	-0.195	+0.113
L	-0.065	+0.252
M	-0.065	+0.113
N	+0.065	+0.113
P	+0.130	+0.000
R	+0.065	-0.113
S	-0.065	-0.113
T	-0.130	+0.000
U	+0.000	+0.000

Connector Type	MIL-DTL-38999 Series I	MIL-DTL-38999 Series II	MIL-DTL-38999 Series III	Number of Contacts	Contact Size	Service Rating
Insert Designation	15-19	N/A	D19	19	20	I

Front face of pin insert shown

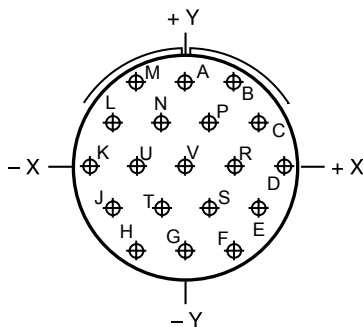

Contact Locations		
Contact Position	Location	
	X-Axis	Y-Axis
A	+0.000	+0.225
B	+0.130	+0.225
C	+0.195	+0.113
D	+0.260	+0.000
E	+0.195	-0.113
F	+0.130	-0.225
G	+0.000	-0.225
H	-0.130	-0.225
J	-0.195	-0.113
K	-0.260	+0.000

Contact Locations		
Contact Position	Location	
	X-Axis	Y-Axis
L	-0.195	+0.113
M	-0.130	+0.225
N	-0.065	+0.113
P	+0.065	+0.113
R	+0.130	+0.000
S	+0.065	-0.113
T	-0.065	-0.113
U	-0.130	+0.000
V	+0.000	+0.000

Alternate PC Tail diameters are available. Refer to PC Tail Specification section starting on 229-234. Dimensional data for the most common insert patterns for the PCB applications are shown. For availability of other insert arrangements, please consult Conesys/Aero-Electric Connector.

Circular Connectors - PCB Contacts

MIL-DTL-38999 Series I, II and III

Insert Arrangements



Connector Type	MIL-DTL-38999 Series I	MIL-DTL-38999 Series II	MIL-DTL-38999 Series III	Number of Contacts	Contact Size	Service Rating
Insert Designation	15-35	14-35	D35	37	22D	M

Front face of pin insert shown

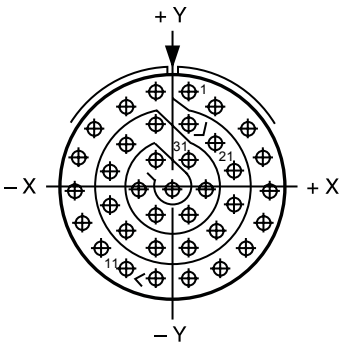

Contact Locations		
Contact Position	Location	
	X-Axis	Y-Axis
1	+045	+262
2	+123	+217
3	+211	+160
4	+254	+080
5	+266	-.010
6	+247	-.098
7	+200	-.175
8	+130	-.232
9	+045	-.262
10	-.045	-.262
11	-.130	-.232
12	-.200	-.175
13	-.247	-.098
14	-.266	-.010
15	-.254	+080
16	-.211	+160
17	-.123	+217
18	-.045	+262
19	+045	+172

Contact Locations		
Contact Position	Location	
	X-Axis	Y-Axis
20	+123	+119
21	+170	+040
22	+170	-.050
23	+123	-.127
24	+045	-.172
25	-.045	-.172
26	-.123	-.127
27	-.170	-.050
28	-.170	+040
29	-.123	+119
30	-.045	+172
31	+045	+074
32	+090	-.004
33	+045	-.082
34	-.045	-.082
35	-.090	-.004
36	-.045	+074
37	+000	-.004

Connector Type	MIL-DTL-38999 Series I	MIL-DTL-38999 Series II	MIL-DTL-38999 Series III	Number of Contacts	Contact Size	Service Rating
Insert Designation	17-26	16-26	E26	26	20	I

Front face of pin insert shown

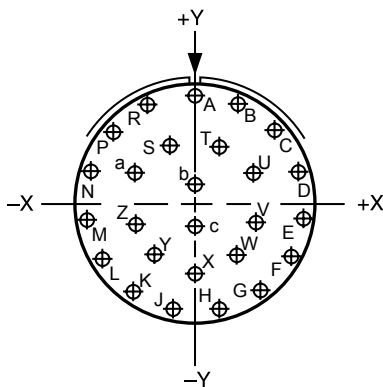

Contact Locations		
Contact Position	Location	
	X-Axis	Y-Axis
A	+000	+321
B	+131	+293
C	+239	+214
D	+305	+099
E	+319	-.034
F	+278	-.161
G	+189	-.260
H	+067	-.314
J	-.067	-.314
K	-.189	-.260
L	-.278	-.161
M	-.319	-.034
N	-.305	+099

Contact Locations		
Contact Position	Location	
	X-Axis	Y-Axis
P	-.239	+214
R	-.131	+293
S	-.070	+177
T	+070	+177
U	+175	+094
V	+178	-.036
W	+119	-.151
X	+000	-.203
Y	-.119	-.151
Z	-.178	-.036
a	-.175	+094
b	+000	+065
c	+000	-.065

Alternate PC Tail diameters are available. Refer to PC Tail Specification section starting on 229-234. Dimensional data for the most common insert patterns for the PCB applications are shown. For availability of other insert arrangements, please consult Conesys/Aero-Electric Connector.

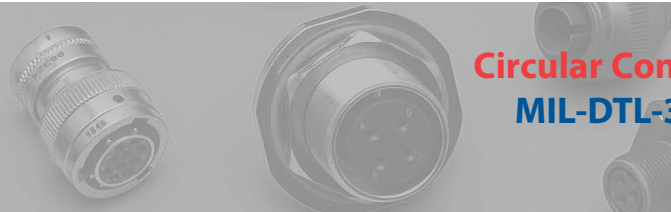

Connector Type	MIL-DTL-38999 Series I	MIL-DTL-38999 Series II	MIL-DTL-38999 Series III	Number of Contacts	Contact Size	Service Rating
Insert Designation	17-35	16-35	E35	55	22D	M

Front face of pin insert shown

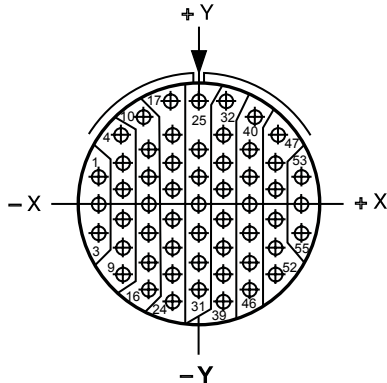

Contact Locations		
Contact Position	Location	
	X-Axis	Y-Axis
1	-.312	+.086
2	-.312	-.004
3	-.312	-.094
4	-.242	+.221
5	-.234	+.131
6	-.234	+.041
7	-.234	-.049

Contact Locations		
Contact Position	Location	
	X-Axis	Y-Axis
8	-.234	-.139
9	-.234	-.229
10	-.172	+.279
11	-.156	+.176
12	-.156	+.086
13	-.156	-.004
14	-.156	-.094
15	-.156	-.184
16	-.156	-.274
17	-.089	+.316
18	-.078	+.221
19	-.078	+.131
20	-.078	+.041
21	-.078	-.049
22	-.078	-.139
23	-.078	-.229
24	-.078	-.319
25	+.000	+.329
26	+.000	+.176
27	+.000	+.086
28	+.000	-.004
29	+.000	-.094
30	+.000	-.184
31	+.000	-.274
32	+.089	+.316

Contact Locations		
Contact Position	Location	
	X-Axis	Y-Axis
33	+.078	+.221
34	+.078	+.131
35	+.078	+.041
36	+.078	-.049
37	+.078	-.139
38	+.078	-.229
39	+.078	-.319
40	+.172	+.279
41	+.156	+.176
42	+.156	+.086
43	+.156	-.004
44	+.156	-.094
45	+.156	-.184
46	+.156	-.274
47	+.242	+.221
48	+.234	+.131
49	+.234	+.041
50	+.234	-.049
51	+.234	-.139
52	+.234	-.229
53	+.312	+.086
54	+.312	-.004
55	+.312	-.094

Connector Type	MIL-DTL-38999 Series I	MIL-DTL-38999 Series II	MIL-DTL-38999 Series III	Number of Contacts	Contact Size	Service Rating
Insert Designation	17-8	16-8	E8	8	16	II

Front face of pin insert shown

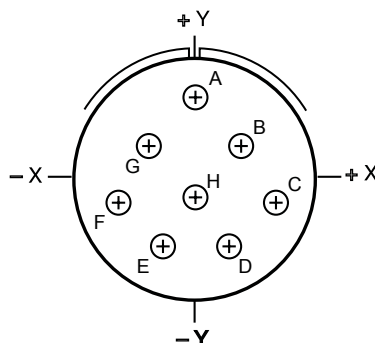

Contact Locations		
Contact Position	Location	
	X-Axis	Y-Axis
A	+.000	+.236
B	+.128	+.086
C	+.230	-.078
D	+.094	-.216
E	-.094	-.216
F	-.230	-.078
G	-.128	+.086
H	+.000	-.052

Alternate PC Tail diameters are available. Refer to PC Tail Specification section starting on 229-234. Dimensional data for the most common insert patterns for the PCB applications are shown. For availability of other insert arrangements, please consult Conesys/Aero-Electric Connector.

Circular Connectors - PCB Contacts

MIL-DTL-38999 Series I, II and III

Insert Arrangements



Connector Type	MIL-DTL-38999 Series I	MIL-DTL-38999 Series II	MIL-DTL-38999 Series III	Number of Contacts	Contact Size	Service Rating
Insert Designation	19-11	18-11	F11	11	16	II

Front face of pin insert shown

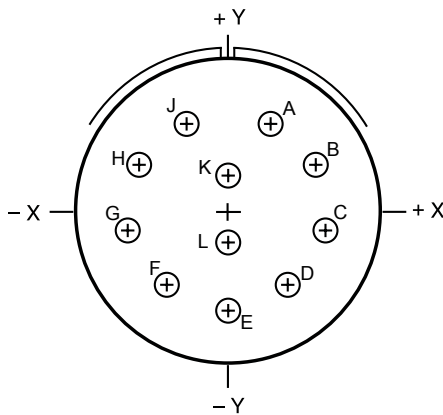

Contact Locations		
Contact Position	Location	
	X-Axis	Y-Axis
A	+ .105	+ .260
B	+ .250	+ .132
C	+ .275	- .053
D	+ .179	- .215
E	+ .000	- .281
F	- .179	- .215
G	- .275	- .053
H	- .250	+ .132
J	- .105	+ .260
K	+ .000	+ .105
L	+ .000	- .092

Connector Type	MIL-DTL-38999 Series I	MIL-DTL-38999 Series II	MIL-DTL-38999 Series III	Number of Contacts	Contact Size	Service Rating
Insert Designation	19-32	18-32	F32	32	20	I

Front face of pin insert shown

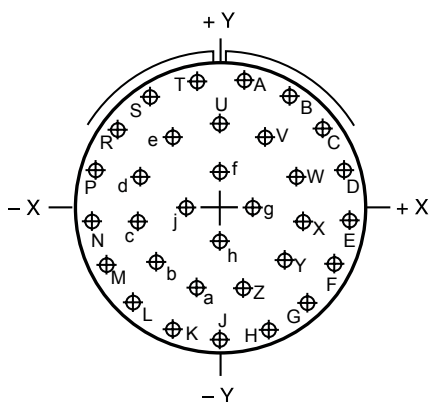

Contact Locations		
Contact Position	Location	
	X-Axis	Y-Axis
A	+ .066	+ .353
B	+ .189	+ .305
C	+ .286	+ .217
D	+ .345	+ .098
E	+ .357	- .033
F	+ .321	- .160
G	+ .242	- .265
H	+ .130	- .335
J	+ .000	- .359
K	- .130	- .335
L	- .242	- .265
M	- .321	- .160
N	- .357	- .033
P	- .345	+ .098
R	- .286	+ .217
S	- .189	+ .305

Contact Locations		
Contact Position	Location	
	X-Axis	Y-Axis
T	- .066	+ .353
U	+ .000	+ .230
V	+ .124	+ .193
W	+ .209	+ .095
X	+ .228	- .033
Y	+ .174	- .151
Z	+ .065	- .221
a	- .065	- .221
b	- .174	- .151
c	- .228	- .033
d	- .209	+ .095
e	- .124	+ .193
f	+ .000	+ .096
g	+ .096	+ .000
h	+ .000	- .096
j	- .096	+ .000

Alternate PC Tail diameters are available. Refer to PC Tail Specification section starting on 229-234. Dimensional data for the most common insert patterns for the PCB applications are shown. For availability of other insert arrangements, please consult Conesys/Aero-Electric Connector.



Circular Connectors - PCB Contacts MIL-DTL-38999 Series I, II and III Insert Arrangements

Connector Type	MIL-DTL-38999 Series I	MIL-DTL-38999 Series II	MIL-DTL-38999 Series III	Number of Contacts	Contact Size	Service Rating
Insert Designation	19-35	18-35	F35	66	22D	M

Front face of pin insert shown

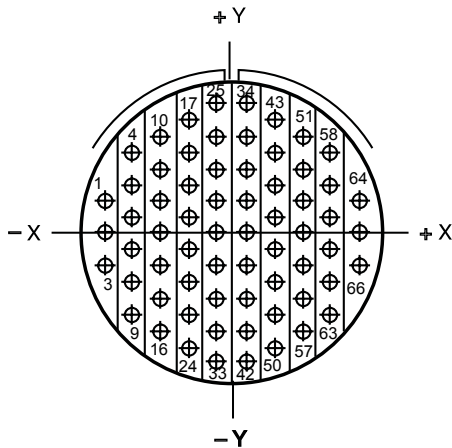

Contact Locations		
Contact Position	Location	
	X-Axis	Y-Axis
1	-0.357	+0.090
2	-0.357	+0.000
3	-0.357	-0.090
4	-0.279	+0.225
5	-0.279	+0.135
6	-0.279	+0.045
7	-0.279	-0.045
8	-0.279	-0.135
9	-0.279	-0.225
10	-0.201	+0.270
11	-0.201	+0.180
12	-0.201	+0.090
13	-0.201	+0.000
14	-0.201	-0.090
15	-0.201	-0.180
16	-0.201	-0.270
17	-0.123	+0.315
18	-0.123	+0.225
19	-0.123	+0.135
20	-0.123	+0.045
21	-0.123	-0.045
22	-0.123	-0.135
23	-0.123	-0.225
24	-0.123	-0.315
25	-0.045	+0.360
26	-0.045	+0.270
27	-0.045	+0.180
28	-0.045	+0.090
29	-0.045	+0.000
30	-0.045	-0.090
31	-0.045	-0.180
32	-0.045	-0.270
33	-0.045	-0.360

Contact Locations		
Contact Position	Location	
	X-Axis	Y-Axis
34	+0.045	+0.360
35	+0.045	+0.270
36	+0.045	+0.180
37	+0.045	+0.090
38	+0.045	+0.000
39	+0.045	-0.090
40	+0.045	-0.180
41	+0.045	-0.270
42	+0.045	-0.360
43	+0.123	+0.315
44	+0.123	+0.225
45	+0.123	+0.135
46	+0.123	+0.045
47	+0.123	-0.045
48	+0.123	-0.135
49	+0.123	-0.225
50	+0.123	-0.315
51	+0.201	+0.270
52	+0.201	+0.180
53	+0.201	+0.090
54	+0.201	+0.000
55	+0.201	-0.090
56	+0.201	-0.180
57	+0.201	-0.270
58	+0.279	+0.225
59	+0.279	+0.135
60	+0.279	+0.045
61	+0.279	-0.045
62	+0.279	-0.135
63	+0.279	-0.225
64	+0.357	+0.090
65	+0.357	+0.000
66	+0.357	-0.090

Alternate PC Tail diameters are available. Refer to PC Tail Specification section starting on 229-234. Dimensional data for the most common insert patterns for the PCB applications are shown. For availability of other insert arrangements, please consult Conesys/Aero-Electric Connector.

Circular Connectors - PCB Contacts

MIL-DTL-38999 Series I, II and III

Insert Arrangements



Connector Type	MIL-DTL-38999 Series I	MIL-DTL-38999 Series II	MIL-DTL-38999 Series III	Number of Contacts	Contact Size	Service Rating
Insert Designation	21-35	20-35	G35	79	22D	M

Front face of pin insert shown

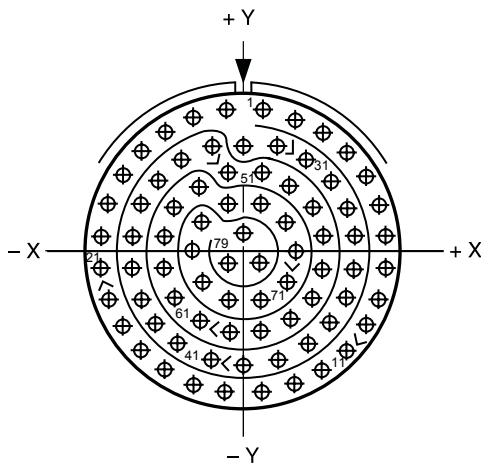

Contact Locations		
Contact Position	Location	
	X-Axis	Y-Axis
1	+0.053	+0.426
2	+0.146	+0.404
3	+0.232	+0.362
4	+0.306	+0.302
5	+0.365	+0.227
6	+0.406	+0.141
7	+0.427	+0.048
8	+0.427	-0.048
9	+0.406	-0.141
10	+0.365	-0.227
11	+0.306	-0.302
12	+0.232	-0.362
13	+0.146	-0.404
14	+0.053	-0.426
15	-0.053	-0.426
16	-0.146	-0.404
17	-0.232	-0.362
18	-0.306	-0.302
19	-0.365	-0.227
20	-0.406	-0.141
21	-0.427	-0.048
22	-0.427	+0.048
23	-0.406	+0.141
24	-0.365	+0.227
25	-0.306	+0.302
26	-0.232	+0.362
27	-0.146	+0.404
28	-0.053	+0.426
29	.000	+0.323
30	+0.098	+0.322
31	+0.184	+0.280
32	+0.258	+0.220
33	+0.311	+0.141
34	+0.332	+0.048
35	+0.332	-0.048
36	+0.311	-0.141
37	+0.258	-0.220
38	+0.184	-0.280
39	+0.098	-0.322
40	.000	-0.347

Contact Locations		
Contact Position	Location	
	X-Axis	Y-Axis
41	-0.098	-0.322
42	-0.184	-0.280
43	-0.258	-0.220
44	-0.311	-0.141
45	-0.332	-0.048
46	-0.332	+0.048
47	-0.311	+0.141
48	-0.258	+0.220
49	-0.184	+0.280
50	-0.098	+0.322
51	-0.048	+0.241
52	+0.048	+0.241
53	+0.134	+0.199
54	+0.208	+0.139
55	+0.237	+0.048
56	+0.237	-0.048
57	+0.208	-0.139
58	+0.134	-0.199
59	+0.048	-0.241
60	-0.048	-0.241
61	-0.134	-0.199
62	-0.208	-0.139
63	-0.237	-0.048
64	-0.237	+0.048
65	-0.208	+0.139
66	-0.134	+0.199
67	-0.048	+0.146
68	+0.048	+0.146
69	+0.125	+0.090
70	+0.155	.000
71	+0.125	-0.090
72	+0.048	-0.146
73	-0.048	-0.146
74	-0.125	-0.090
75	-0.155	.000
76	-0.125	+0.090
77	.000	+0.053
78	+0.048	-0.029
79	-0.048	-0.029

Alternate PC Tail diameters are available. Refer to PC Tail Specification section starting on 229-234. Dimensional data for the most common insert patterns for the PCB applications are shown. For availability of other insert arrangements, please consult Conesys/Aero-Electric Connector.



Circular Connectors - PCB Contacts
MIL-DTL-38999 Series I, II and III
Insert Arrangements

Connector Type	MIL-DTL-38999 Series I	MIL-DTL-38999 Series II	MIL-DTL-38999 Series III	Number of Contacts	Contact Size	Service Rating
Insert Designation	21-41	20-41	G41	41	20	I

Front face of pin insert shown

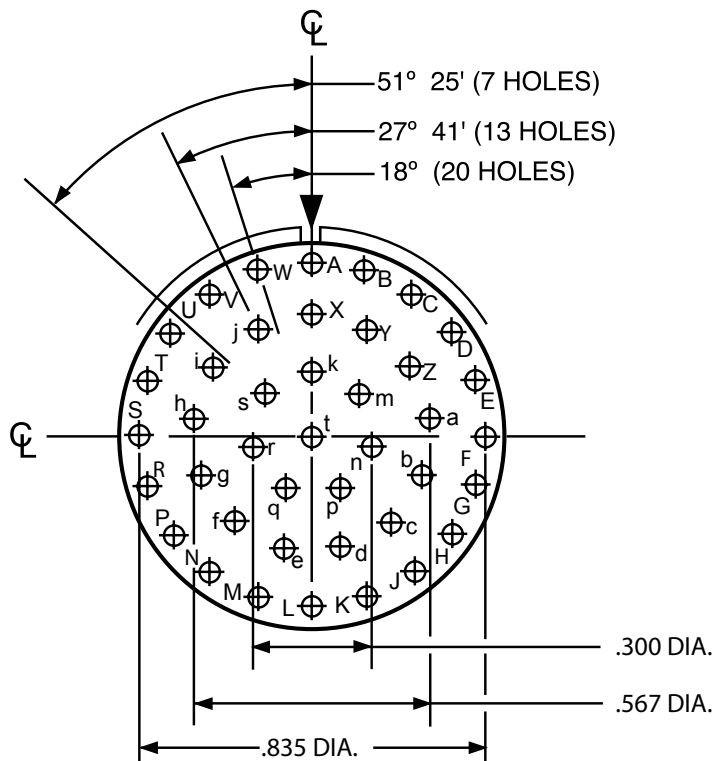

Alternate PC Tail diameters are available. Refer to PC Tail Specification section starting on 229-234. Dimensional data for the most common insert patterns for the PCB applications are shown. For availability of other insert arrangements, please consult Conesys/Aero-Electric Connector.

Circular Connectors - PCB Contacts

MIL-DTL-38999 Series I, II and III

Insert Arrangements



Connector Type	MIL-DTL-38999 Series I	MIL-DTL-38999 Series II	MIL-DTL-38999 Series III	Number of Contacts	Contact Size	Service Rating
Insert Designation	23-35	22-35	H35	100	22D	M

Front face of pin insert shown

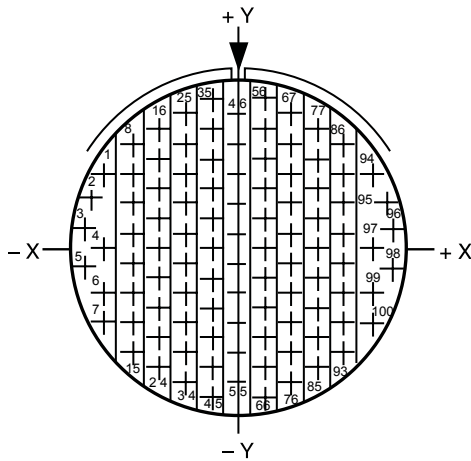

Contact Locations		
Contact Positions	Location	
	X-Axis	Y-Axis
1	-.428	+.241
2	-.467	+.154
3	-.488	+.061
4	-.415	.000
5	-.488	-.061
6	-.428	-.142
7	-.428	-.237
8	-.332	+.333
9	-.332	+.238
10	-.332	+.143
11	-.332	+.048
12	-.332	-.047
13	-.332	-.142
14	-.332	-.237
15	-.332	-.332
16	-.249	+.380
17	-.249	+.285
18	-.249	+.190
19	-.249	+.095
20	-.249	.000
21	-.249	-.095
22	-.249	-.190
23	-.249	-.285
24	-.249	-.380
25	-.166	+.428
26	-.166	+.333

Contact Locations		
Contact Positions	Location	
	X-Axis	Y-Axis
27	-.166	+.238
28	-.166	+.143
29	-.166	+.048
30	-.166	-.047
31	-.166	-.142
32	-.166	-.237
33	-.166	-.332
34	-.166	-.427
35	-.083	+.475
36	-.083	+.380
37	-.083	+.285
38	-.083	+.190
39	-.083	+.095
40	-.083	.000
41	-.083	-.095
42	-.083	-.190
43	-.083	-.285
44	-.083	-.380
45	-.083	-.475
46	.000	+.428
47	.000	+.333
48	.000	+.238
49	.000	+.143
50	.000	+.048
51	.000	-.047
52	.000	-.142
53	.000	-.237
54	.000	-.332
55	.000	-.427
56	+.083	+.475
57	+.083	+.380
58	+.083	+.285
59	+.083	+.190
60	+.083	+.095
61	+.083	.000
62	+.083	-.095
63	+.083	-.190
64	+.083	-.285
65	+.083	-.380
66	+.083	-.475
67	+.166	+.428
68	+.166	+.333
69	+.166	+.238
70	+.166	+.143
71	+.166	+.048
72	+.166	-.047
73	+.166	-.142
74	+.166	-.237

Contact Locations		
Contact Positions	Location	
	X-Axis	Y-Axis
75	+.166	-.332
76	+.166	-.427
77	+.249	+.380
78	+.249	+.285
79	+.249	+.190
80	+.249	+.095
81	+.249	.000
82	+.249	-.095
83	+.249	-.190
84	+.249	-.285
85	+.249	-.380
86	+.332	+.333
87	+.332	+.238
88	+.332	+.143
89	+.332	+.048
90	+.332	-.047
91	+.332	-.142
92	+.332	-.237
93	+.332	-.332
94	+.428	+.241
95	+.467	+.154
96	+.488	+.061
97	+.415	.000
98	+.488	-.061
99	+.428	-.142
100	+.428	-.237

Alternate PC Tail diameters are available. Refer to PC Tail Specification section starting on 229-234. Dimensional data for the most common insert patterns for the PCB applications are shown. For availability of other insert arrangements, please consult Conesys/Aero-Electric Connector.



Circular Connectors - PCB Contacts MIL-DTL-38999 Series I, II and III Insert Arrangements

Connector Type	MIL-DTL-38999 Series I	MIL-DTL-38999 Series II	MIL-DTL-38999 Series III	Number of Contacts	Contact Size	Service Rating
Insert Designation	23-55	22-55	H55	55	20	I

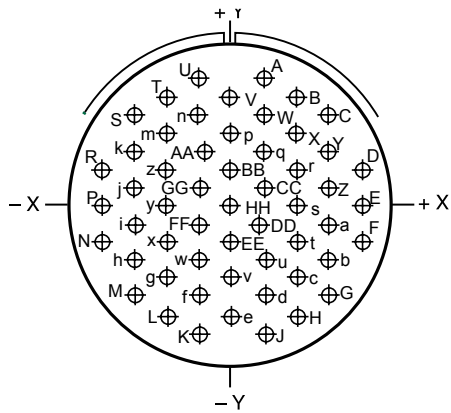

Contact Locations		
Contact Position	Location	
	X-Axis	Y-Axis
A	+1.112	+4.455
B	+2.225	+3.390
C	+3.336	+3.325
D	+4.450	+1.130
E	+4.450	+0.000
F	+4.450	-1.130
G	+3.336	-3.325

Contact Locations		
Contact Position	Location	
	X-Axis	Y-Axis
H	+2.225	-3.390
J	+1.112	-4.455
K	-.112	-4.455
L	-.225	-3.390
M	-.336	-.325
N	-.450	-.130
P	-.450	+0.000
R	-.450	+1.130
S	-.336	+3.325
T	-.225	+3.390
U	-.112	+4.455
V	+0.000	+3.390
W	+1.112	+3.325
X	+2.225	+2.60
Y	+3.336	+1.195
Z	+3.336	+0.065
a	+3.336	-.065
b	+3.336	-.195
c	+2.225	-.260
d	+1.112	-.325
e	+0.000	-.390
f	-.112	-.325
g	-.225	-.260
h	-.336	-.195

Contact Locations		
Contact Position	Location	
	X-Axis	Y-Axis
i	-.336	-.065
j	-.336	+0.065
k	-.336	+1.195
m	-.225	+2.60
n	-.112	+3.325
p	+0.000	+2.60
q	+1.112	+1.195
r	+2.225	+1.130
s	+2.225	+0.000
t	+2.225	-.130
u	+1.112	-.195
v	+0.000	-.260
w	-.112	-.195
x	-.225	-.130
y	-.225	+0.000
z	-.225	+1.130
AA	-.112	+1.195
BB	+0.000	+1.130
CC	+1.112	+0.065
DD	+1.112	-.065
EE	+0.000	-.130
FF	-.112	-.065
GG	-.112	+0.065
HH	+0.000	+0.000

Connector Type	MIL-DTL-38999 Series I	MIL-DTL-38999 Series II	MIL-DTL-38999 Series III	Number of Contacts	Contact Size	Service Rating
Insert Designation	25-29	24-29	J29	29	16	I

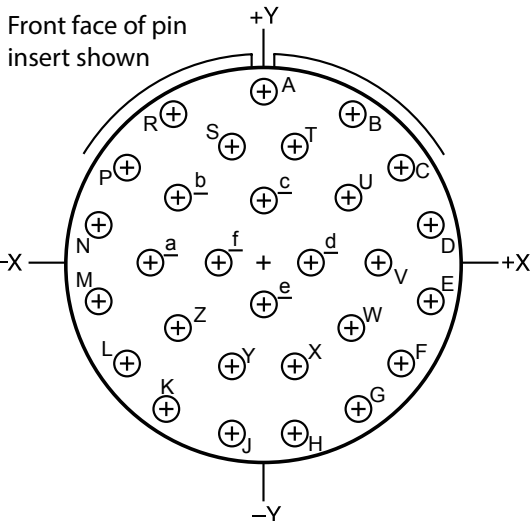

Contact Locations		
Contact Position	Location	
	X-Axis	Y-Axis
A	+0.000	+4.481
B	+2.258	+4.406
C	+3.395	+2.277
D	+4.469	+1.109
E	+4.469	-.109
F	+3.395	-.277
G	+2.263	-.406
H	+0.091	-.472
J	-.091	-.472
K	-.263	-.406
L	-.395	-.277
M	-.469	-.109
N	-.469	+1.109
P	-.395	+2.277
R	-.258	+4.406

Contact Locations		
Contact Position	Location	
	X-Axis	Y-Axis
S	-.091	+3.321
T	+0.091	+3.321
U	+2.228	+1.194
V	+3.319	+0.000
W	+2.240	-.181
X	+0.091	-.290
Y	-.091	-.290
Z	-.240	-.181
a	-.319	+0.000
b	-.228	+1.194
c	+0.000	+1.161
d	+1.134	+0.000
e	+0.000	-.130
f	-.134	+0.000

Alternate PC Tail diameters are available. Refer to PC Tail Specification section starting on 229-234. Dimensional data for the most common insert patterns for the PCB applications are shown. For availability of other insert arrangements, please consult Conesys/Aero-Electric Connector.

Circular Connectors - PCB Contacts

MIL-DTL-38999 Series I, II and III

Insert Arrangements



Connector Type	MIL-DTL-38999 Series I	MIL-DTL-38999 Series II	MIL-DTL-38999 Series III	Number of Contacts	Contact Size	Service Rating
Insert Designation	25-35	24-35	J35	128	22D	M

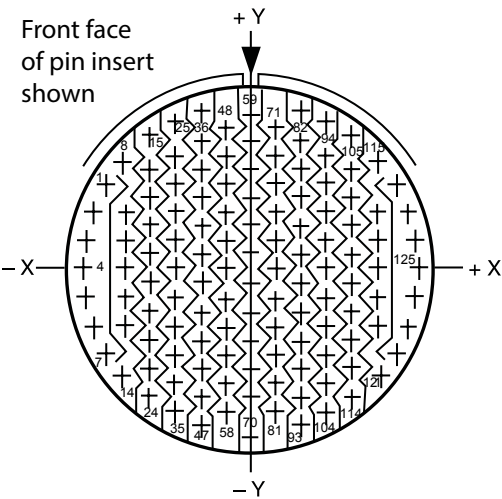

Contact Locations		
Contact Position	Location	
	X-Axis	Y-Axis
1	-.479	+.279
2	-.520	+.190
3	-.546	+.095
4	-.555	.000
5	-.546	-.095
6	-.520	-.190
7	-.479	-.279
8	-.424	+.357
9	-.415	+.190
10	-.415	+.095
11	-.415	.000
12	-.415	-.095
13	-.415	-.190
14	-.424	-.357
15	-.332	+.444
16	-.332	+.332
17	-.332	+.237
18	-.332	+.142
19	-.332	+.047
20	-.332	-.047
21	-.332	-.142
22	-.332	-.237
23	-.332	-.332
24	-.332	-.427
25	-.249	+.496
26	-.249	+.380

Contact Locations		
Contact Position	Location	
	X-Axis	Y-Axis
27	-.249	+.285
28	-.249	+.190
29	-.249	+.095
30	-.249	.000
31	-.249	-.095
32	-.249	-.190
33	-.249	-.285
34	-.249	-.380
35	-.249	-.475
36	-.166	+.531
37	-.166	+.427
38	-.166	+.332
39	-.166	+.237
40	-.166	+.142
41	-.166	+.047
42	-.166	-.047
43	-.166	-.142
44	-.166	-.237
45	-.166	-.332
46	-.166	-.427
47	-.166	-.522
48	-.083	+.475
49	-.083	+.380
50	-.083	+.285
51	-.083	+.190
52	-.083	+.095
53	-.083	.000
54	-.083	-.095
55	-.083	-.190
56	-.083	-.285
57	-.083	-.380
58	-.083	-.475
59	.000	+.522
60	.000	+.427
61	.000	+.332
62	.000	+.237
63	.000	+.142
64	.000	+.047
65	.000	-.047
66	.000	-.142
67	.000	-.237
68	.000	-.332
69	.000	-.427
70	.000	-.555
71	+.083	+.475
72	+.083	+.380
73	+.083	+.285
74	+.083	+.190
75	+.083	+.095
76	+.083	.000
77	+.083	-.095

Contact Locations		
Contact Position	Location	
	X-Axis	Y-Axis
78	+.083	-.190
79	+.083	-.285
80	+.083	-.380
81	+.083	-.475
82	+.166	+.531
83	+.166	+.427
84	+.166	+.332
85	+.166	+.237
86	+.166	+.142
87	+.166	+.047
88	+.166	-.047
89	+.166	-.142
90	+.166	-.237
91	+.166	-.332
92	+.166	-.427
93	+.166	-.522
94	+.249	+.496
95	+.249	+.380
96	+.249	+.285
97	+.249	+.190
98	+.249	+.095
99	+.249	.000
100	+.249	-.095
101	+.249	-.190
102	+.249	-.285
103	+.249	-.380
104	+.249	-.475
105	+.332	+.444
106	+.332	+.332
107	+.332	+.237
108	+.332	+.142
109	+.332	+.047
110	+.332	-.047
111	+.332	-.142
112	+.332	-.237
113	+.332	-.332
114	+.332	-.427
115	+.424	+.357
116	+.415	+.190
117	+.415	+.095
118	+.415	.000
119	+.415	-.095
120	+.415	-.190
121	+.424	-.357
122	+.479	+.279
123	+.520	+.190
124	+.546	+.095
125	+.555	.000
126	+.546	-.095
127	+.520	-.190
128	+.479	-.279

Alternate PC Tail diameters are available. Refer to PC Tail Specification section starting on 229-234. Dimensional data for the most common insert patterns for the PCB applications are shown. For availability of other insert arrangements, please consult Conesys/Aero-Electric Connector.

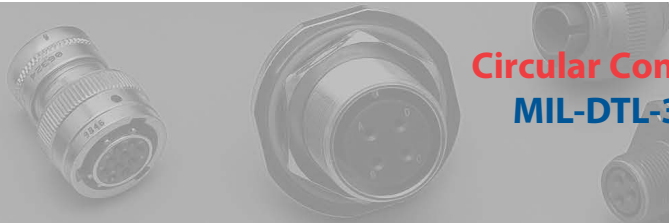

Circular Connectors - PCB Contacts MIL-DTL-38999 Series I, II and III Insert Arrangements

Connector Type	MIL-DTL-38999 Series I	MIL-DTL-38999 Series II	MIL-DTL-38999 Series III	Number of Contacts	Contact Size	Service Rating
Insert Designation	25-61	24-61	J61	61	20	I

Front face of pin insert shown

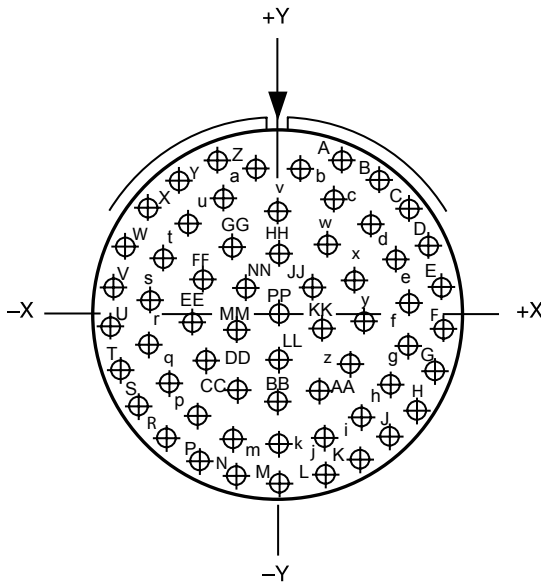

Contact Locations		
Contact Position	Location	
	X-Axis	Y-Axis
Z	-.196	+.500
a	-.068	+.454
b	+.068	+.454
c	+.173	+.363
d	+.285	+.283
e	+.362	+.175
f	+.399	+.046
g	+.392	-.088
h	+.341	-.213
i	+.251	-.314
j	+.133	-.379
k	+.000	-.402
m	-.133	-.379
n	-.251	-.314
p	-.341	-.213
q	-.392	-.088
r	-.399	+.046
s	-.362	+.175
t	-.285	+.283
u	-.173	+.363
v	+.000	+.338
w	+.147	+.223
x	+.237	+.122
y	+.267	-.010
z	+.228	-.139
AA	+.131	-.233
BB	+.000	-.267
CC	-.131	-.233
DD	-.228	-.139
EE	-.267	-.010
FF	-.237	+.122
GG	-.147	+.223
HH	+.000	+.200
JJ	+.105	+.094
KK	+.135	-.041
LL	+.000	-.132
MM	-.135	-.041
NN	-.105	+.094
PP	+.000	+.000

Contact Locations		
Contact Position	Location	
	X-Axis	Y-Axis
A	+.196	+.500
B	+.314	+.435
C	+.413	+.343
D	+.485	+.230
E	+.527	+.101
F	+.536	-.030
G	+.511	-.164
H	+.454	-.287
J	+.368	-.391
K	+.259	-.470
L	+.134	-.519

Contact Locations		
Contact Position	Location	
	X-Axis	Y-Axis
M	+.000	-.537
N	-.134	-.519
P	-.259	-.470
R	-.368	-.391
S	-.454	-.287
T	-.511	-.164
U	-.536	-.030
V	-.527	+.101
W	-.485	+.230
X	-.413	+.343
Y	-.314	+.435

Alternate PC Tail diameters are available. Refer to PC Tail Specification section starting on 229-234. Dimensional data for the most common insert patterns for the PCB applications are shown. For availability of other insert arrangements, please consult Conesys/Aero-Electric Connector.

MIL-DTL-26482 Series II Wall Mounting Receptacle AEP15-101, AEP15-102



Part Number Development

Aero Prefix	AEP15-	101-	W	20	XX	P	W-	***
Shell Type								
101 = Rear, wall mount								
102 = Rear, wall mount								
Material Finish								
BN = Aluminum, Black Nickel, (RoHS)								
L = Aluminum, Electroless Nickel								
T = Aluminum, Teflon Nickel (consult factory for availability)								
W = Aluminum, Cadmium, Olive Drab								
Z = Aluminum, Black Zinc Nickel, (RoHS), (consult factory for availability)								
Shell Size								
8, 10, 12, 14, 16, 18, 20, 22, 24								
Insert Arrangement								
Per MIL-STD-1669. 216 Thru 228 for Insert Selection.								
Contact Style								
P = Pin								
S = Socket								
Polarization (Keying)								
N = Normal = Blank								
Alternative Polarization = W, X, Y and Z								
Options (Aero Modification Number)								
***Consult factory for other modifications								

AEP15-101 and -102 Dimensional Data

SHELL SIZE	A MAX.	B	C MAX.	ØD (AEP15-101)	ØJ MAX.	ØU MAX.
8	.828	.594	1.062	.120	.474	.500
10	.964	.719	1.062	.120	.591	.627
12	1.047	.812	1.062	.120	.751	.751
14	1.141	.906	1.062	.120	.876	.876
16	1.234	.969	1.062	.120	1.001	1.001
18	1.328	1.062	1.062	.120	1.126	1.063
20	1.453	1.156	1.124	.147	1.251	1.188
22	1.578	1.250	1.124	.147	1.376	1.313
24	1.703	1.375	1.124	.147	1.501	1.438

Standard PC Tail Diameters

CONTACT SIZE	ØF ±.001
20	.019
16	.062

Alternate PC Tail diameters and lengths are available. Refer to PC Tail Specification section starting on 229-234 for further information, or consult Conesys/Aero Electric Connector for application support.

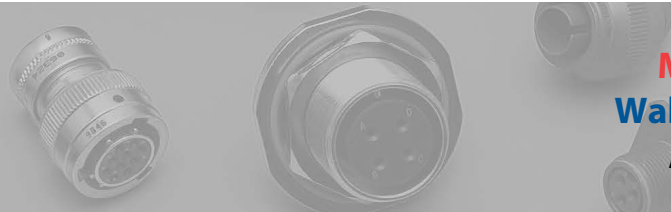

AEP15-101 Receptacle Connector, Wall Mount

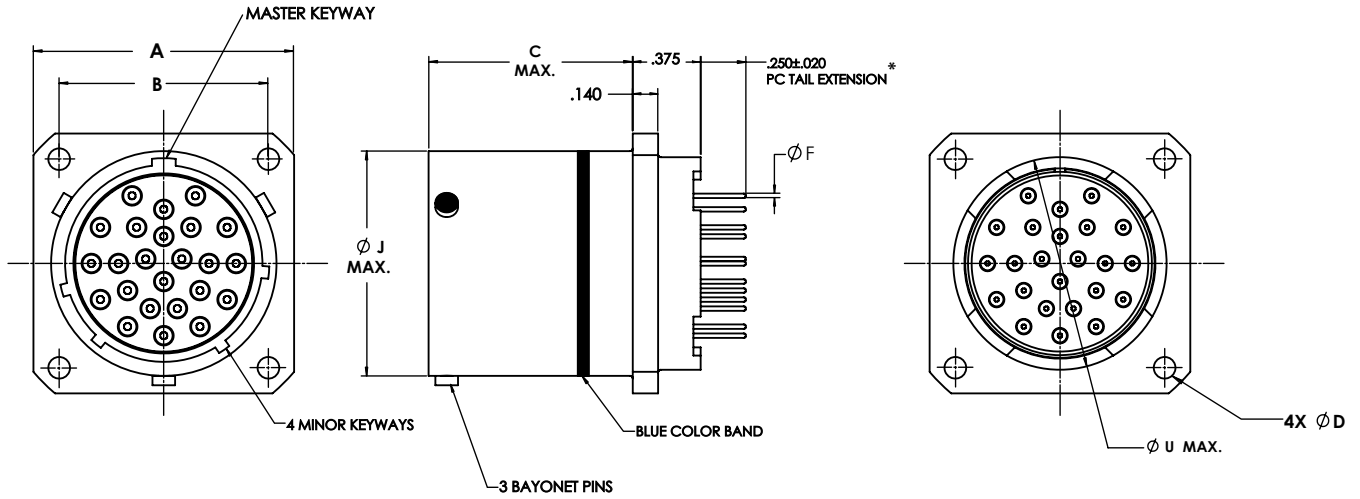

AEP15-102 Receptacle Connector, Wall Mount with Clinch Nuts

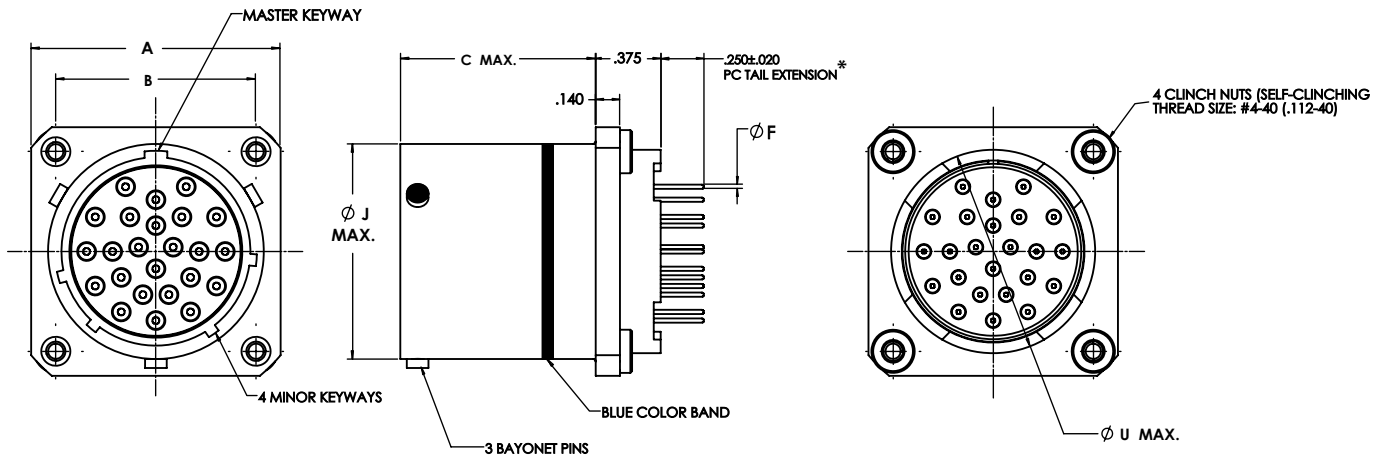

AEP15-101

AEP15-102

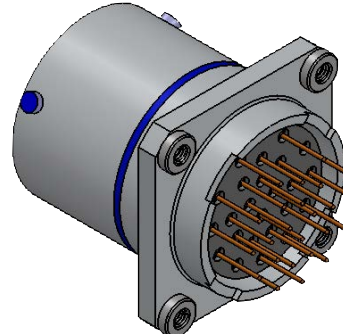
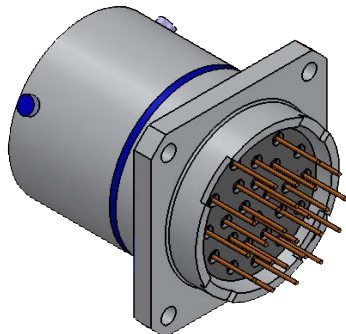

* Standard PC tail extension length. For optional lengths, see pages 229-234 for further information

MIL-DTL-26482 Series II Wall Mounting Receptacle AEP15-103, AEP15-104



Part Number Development

Aero Prefix	AEP15-	103-	W	20	XX	P	W-	***
Shell Type								
103 = Rear, wall mount								
104 = Rear, wall mount								
Material Finish								
BN = Aluminum, Black Nickel, (RoHS)								
L = Aluminum, Electroless Nickel								
T = Aluminum, Teflon Nickel, (RoHS), (consult factory for availability)								
W = Aluminum, Cadmium, Olive Drab								
Z = Aluminum, Black Zinc Nickel, (RoHS), (consult factory for availability)								
Shell Size								
8, 10, 12, 14, 16, 18, 20, 22, 24								
Insert Arrangement								
Per MIL-STD-1669. See Pages 216 Thru 228 for Insert Selection.								
Contact Style								
P = Pin								
S = Socket								
Polarization (Keying)								
N = Normal = Blank								
Alternative Polarization = W, X, Y and Z								
Options (Aero Modification Number)								
***Consult factory for other modifications								

PCB

AEP15-103 and -104 Dimensional Data

SHELL SIZE	A MAX.	B	C MAX.	ØD (AEP15-103)	F	ØJ MAX.	ØU MAX.
8	.828	.594	1.062	.120	.556	.474	.500
10	.964	.719	1.062	.120	.686	.591	.627
12	1.047	.812	1.062	.120	.802	.751	.751
14	1.141	.906	1.062	.120	.927	.876	.876
16	1.234	.969	1.062	.120	1.048	1.001	1.001
18	1.328	1.062	1.062	.120	1.126	1.126	1.063
20	1.453	1.156	1.124	.147	1.250	1.251	1.188
22	1.578	1.250	1.124	.147	1.387	1.376	1.313
24	1.703	1.375	1.124	.147	1.500	1.501	1.438

Standard PC Tail Diameters

CONTACT SIZE	ØG ± .001
20	.019
16	.062

Alternate PC Tail diameters and lengths are available. Refer to PC Tail Specification section starting on 229-234 for further information, or consult Conesys/Aero Electric Connector for application support.



AEP15-103 Receptacle Connector, Wall Mount with Dual Flange

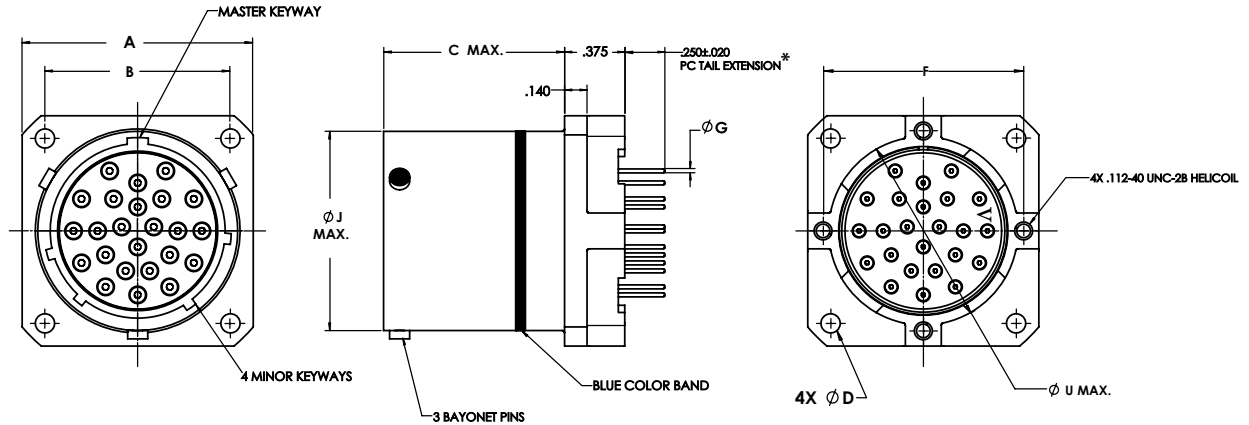

AEP15-104 Receptacle Connector, Wall Mount with Dual Flange and Clinch Nuts

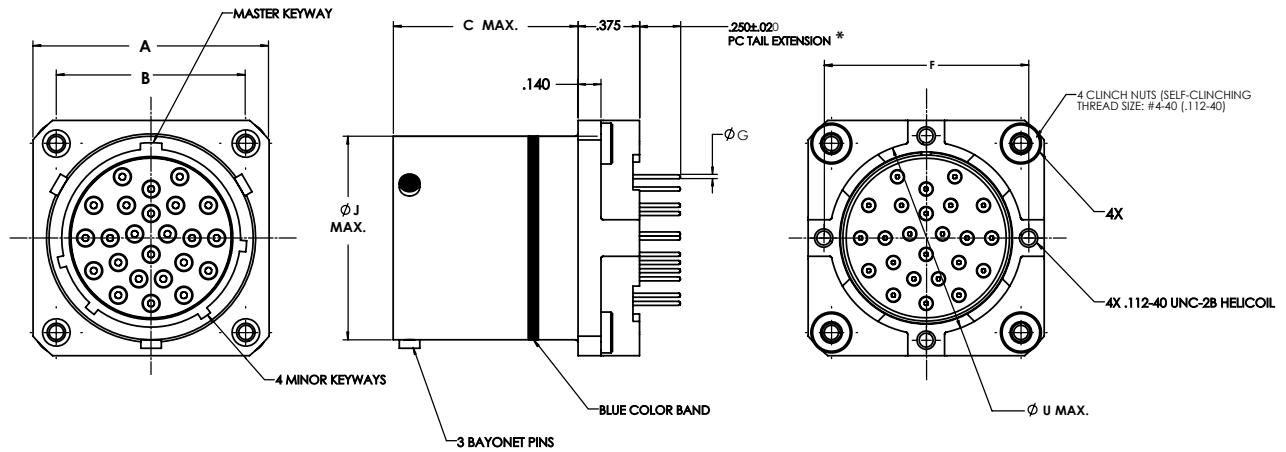

AEP15-103

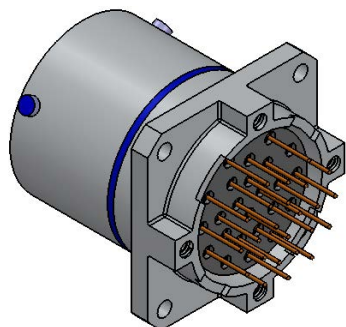

AEP15-104

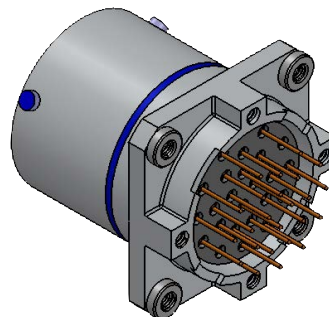

* Standard PC tail extension length. For optional lengths, see pages 229-234 for further information

MIL-DTL-26482 Series II
Jam Nut Receptacle
AEP15-105, AEP15-106



Part Number Configuration

Aero Prefix	AEP15-	105-	W	20	XX	P	W-	***
Shell Type								
105 = Jam nut mount								
106 = Jam nut mount								
Material Finish								
BN = Aluminum, Black Nickel, (RoHS)								
L = Aluminum, Electroless Nickel								
T = Aluminum, Teflon Nickel, (RoHS), (consult factory for availability)								
W = Aluminum, Cadmium, Olive Drab								
Z = Aluminum, Black Zinc Nickel, (RoHS), (consult factory for availability)								
Shell Size								
8, 10, 12, 14, 16, 18, 20, 22, 24								
Insert Arrangement								
Per MIL-STD-1669. See Pages 216 Thru 228 for Insert Selection.								
Contact Style								
P = Pin								
S = Socket								
Polarization (Keying)								
N = Normal = Blank								
Alternative Polarization = W, X, Y and Z								
Options (Aero Modification Number)								
***Consult factory for other modifications								

AEP15-105 and -106 Dimensional Data

SHELL SIZE	A MAX.	ØB MAX.	ØC MAX.	F FLAT	G THREAD-UNEF-2A	ØJ MAX.	p (AEP15-106)	ØU MAX.
8	.954	1.078	1.062	.525	.562-24	.474	.556	.500
10	1.078	1.230	1.062	.650	.687-24	.591	.686	.627
12	1.266	1.391	1.062	.813	.875-20	.751	.802	.751
14	1.391	1.516	1.062	.937	1.000-20	.876	.927	.876
16	1.516	1.641	1.062	1.061	1.125-18	1.001	1.048	1.001
18	1.641	1.766	1.062	1.186	1.250-18	1.126	1.126	1.063
20	1.828	1.954	1.124	1.311	1.375-18	1.251	1.250	1.188
22	1.954	2.078	1.124	1.436	1.500-18	1.376	1.387	1.313
24	2.078	2.203	1.124	1.561	1.625-18	1.501	1.500	1.438

Alternate PC Tail diameters and lengths are available. Refer to PC Tail Specification section starting on 229-234 for further information, or consult Conesys/Aero Electric Connector for application support.

Standard PC Tail Diameters

CONTACT SIZE	ØH ±.001
20	.019
16	.062

AEP15-105 Receptacle Connector, Jam Nut

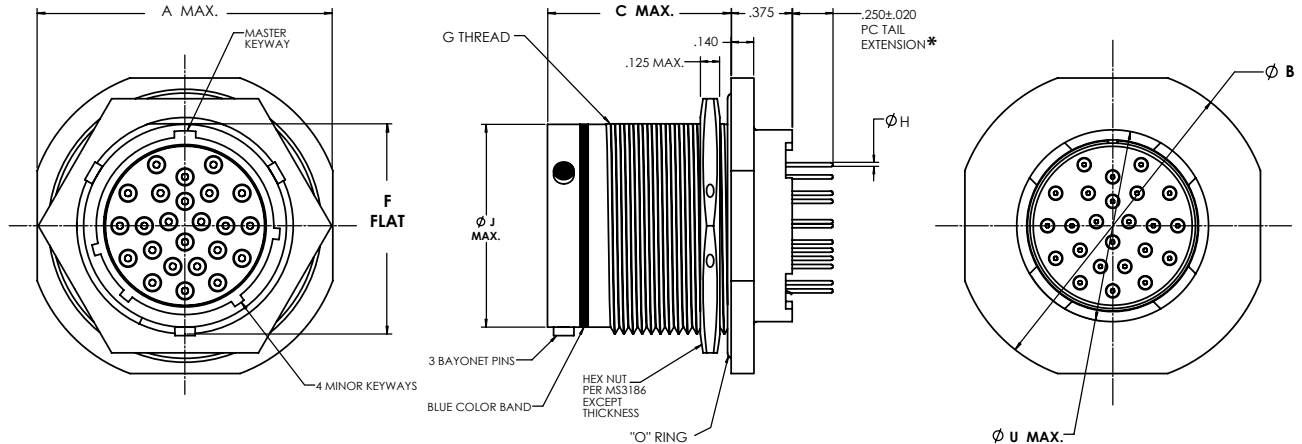

AEP15-106 Receptacle Connector, Jam Nut with Dual Flange

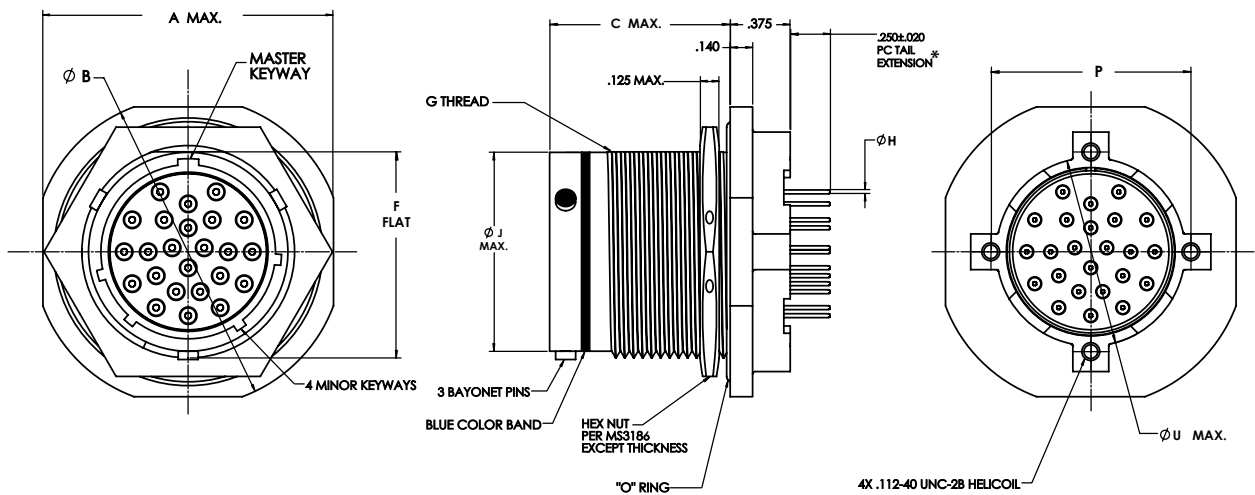

AEP15-105

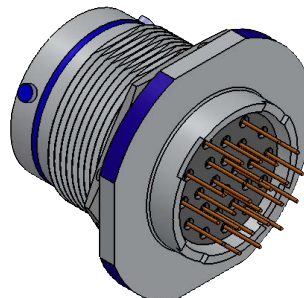

AEP15-106

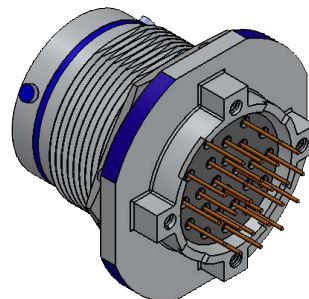

* Standard PC tail extension length. For optional lengths, see pages 229-234 for further information
www.conesys.com

Circular Connectors - PCB Contacts
MIL-DTL-26482
Insert Arrangements - Per MIL-STD-1669



The following table lists the most commonly used insert arrangements for printed circuit board applications using MIL-DTL-26482 circular connectors. Specific dimensional illustrations are included on the following pages for each of the insert arrangements in the table. For availability of other insert arrangements or for application support, please consult Conesys/Aero Electric Connector.

MIL-DTL-26482	Service Rating	Total Contacts	Contact Size	
			20	16
8-2	I	2	2	
8-3	I	3	3	
8-4	I	4	4	
8-33	I	3	3	
8-98	I	3	3	
10-6	I	6	6	
12-3	II	3		3
12-10	I	10	10	
14-5	II	5		5
14-18	I	18	18	
14-19	I	19	19	
16-8	II	8		8
16-26	I	26	26	
18-11	II	11		11
18-32	I	32	32	
20-16	II	16		16
20-24	I	24	24	
20-41	I	41	41	
22-21	II	21		21
22-55	I	55	55	
24-31	I	31		31
24-61	I	61	61	

*For information on size 12 or larger PC Tail contacts, please consult Conesys/Aero-Electric Connector.

Voltage Rating

Service Rating	Suggested Operating Voltage**		Test Voltage	Test Voltage	Test Voltage	Test Voltage
	(Sea Level)		Sea Level	50,000 Ft.	70,000 Ft.	110,000 Ft.
	AC (RMS)	DC	V RMS	V RMS	V RMS	V RMS
I	600	850	1,500	500	375	200
II	1,000	1,275	2,300	750	500	200

** To be used by designer only as a guide.



Circular Connectors - PCB Contacts
MIL-DTL-26482 Series II
Insert Arrangements

PCB

Connector Type	MIL-DTL-26482 Series II	Number of Contacts	Contact Size	Service Rating
Insert Designation	8-2	2	20	I

Front face of pin insert shown

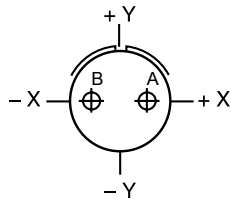

Contact Locations		
Contact Position	Location	
	X-Axis	Y-Axis
A	+0.059	.000
B	-.059	.000

Connector Type	MIL-DTL-26482 Series II	Number of Contacts	Contact Size	Service Rating
Insert Designation	8-3	3	20	I

Front face of pin insert shown

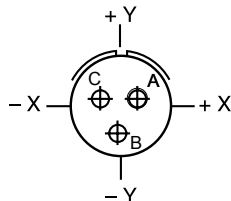

Contact Locations		
Contact Position	Location	
	X-Axis	Y-Axis
A	+0.056	+0.018
B	-.079	.000
C	-.056	+0.018

Alternate PC Tail diameters are available. Refer to PC Tail Specification section starting on 229-234. Dimensional data for the most common insert patterns for the PCB applications are shown. For availability of other insert arrangements, please consult Conesys/Aero-Electric Connector.

Circular Connectors - PCB Contacts

MIL-DTL-26482 Series II

Insert Arrangements



PCB

Connector Type	MIL-DTL-26482 Series II	Number of Contacts	Contact Size	Service Rating
Insert Designation	8-4	4	20	I

Front face of pin insert shown

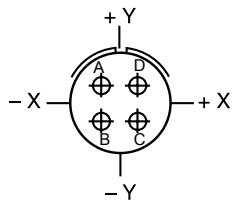

Contact Locations		
Contact Position	Location	
	X-Axis	Y-Axis
A	-.056	+.056
B	-.056	-.056
C	+.056	-.056
D	+.056	+.056

Connector Type	MIL-DTL-26482 Series II	Number of Contacts	Contact Size	Service Rating
Insert Designation	8-33	3	20	I

Front face of pin insert shown

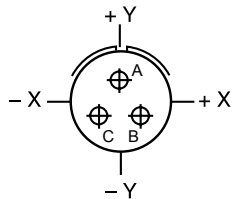

Contact Locations		
Contact Position	Location	
	X-Axis	Y-Axis
A	+.000	+.075
B	+.065	-.038
C	-.065	-.038

Alternate PC Tail diameters are available. Refer to PC Tail Specification section starting on 229-234. Dimensional data for the most common insert patterns for the PCB applications are shown. For availability of other insert arrangements, please consult Conesys/Aero-Electric Connector.

Connector Type	MIL-DTL-26482 Series II	Number of Contacts	Contact Size	Service Rating
Insert Designation	8-98	3	20	I

Front face of pin insert shown

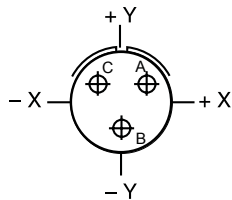

Contact Locations		
Contact Position	Location	
	X-Axis	Y-Axis
A	+0.065	+0.037
B	.000	-.075
C	+0.065	+0.037

Connector Type	MIL-DTL-26482 Series II	Number of Contacts	Contact Size	Service Rating
Insert Designation	10-6	6	20	I

Front face of pin insert shown

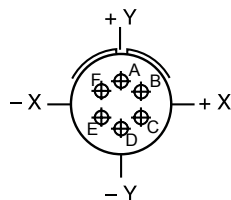

Contact Locations		
Contact Position	Location	
	X-Axis	Y-Axis
A	.000	+0.130
B	+0.113	+0.065
C	+0.113	-0.065
D	.000	-0.130
E	-0.113	-0.065
F	-0.113	+0.065

Alternate PC Tail diameters are available. Refer to PC Tail Specification section starting on 229-234. Dimensional data for the most common insert patterns for the PCB applications are shown. For availability of other insert arrangements, please consult Conesys/Aero-Electric Connector.

Circular Connectors - PCB Contacts

MIL-DTL-26482 Series II

Insert Arrangements



PCB

Connector Type	MIL-DTL-26482 Series II	Number of Contacts	Contact Size	Service Rating
Insert Designation	12-3	3	16	II

Front face of pin insert shown

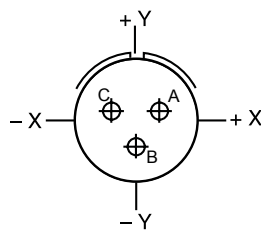

Contact Locations		
Contact Position	Location	
	X-Axis	Y-Axis
A	+094	+058
B	.000	-.111
C	-.094	+058

Connector Type	MIL-DTL-26482 Series II	Number of Contacts	Contact Size	Service Rating
Insert Designation	12-10	10	20	I

Front face of pin insert shown

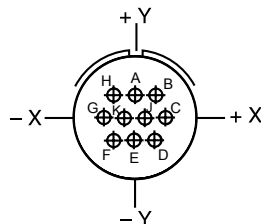

Contact Locations		
Contact Position	Location	
	X-Axis	Y-Axis
A	.000	+.120
B	+.130	+.120
C	+.195	.000
D	+.130	-.120
E	.000	-.120
F	-.130	-.120
G	-.195	.000
H	-.130	+.120
J	+.065	.000
K	-.065	.000

Alternate PC Tail diameters are available. Refer to PC Tail Specification section starting on 229-234. Dimensional data for the most common insert patterns for the PCB applications are shown. For availability of other insert arrangements, please consult Conesys/Aero-Electric Connector.



Connector Type	MIL-DTL-26482 Series II	Number of Contacts	Contact Size	Service Rating
Insert Designation	14-5	5	16	II

Front face of pin insert shown

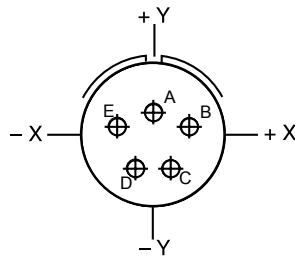

Contact Locations		
Contact Position	Location	
	X-Axis	Y-Axis
A	.000	+.100
B	+.174	+.024
C	+.094	-.148
D	-.094	-.148
E	-.174	+.024

Connector Type	MIL-DTL-26482 Series II	Number of Contacts	Contact Size	Service Rating
Insert Designation	14-18	18	20	I

Front face of pin insert shown

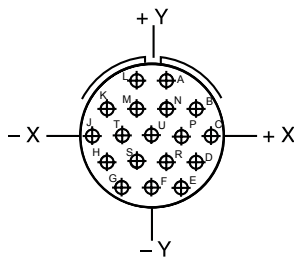

Contact Locations		
Contact Position	Location	
	X-Axis	Y-Axis
A	+.065	+.252
B	+.195	+.113
C	+.260	.000
D	+.195	-.113
E	+.130	-.225
F	.000	-.225
G	-.130	-.225
H	-.195	-.113
J	-.260	.000

Contact Locations		
Contact Position	Location	
	X-Axis	Y-Axis
K	-.195	+.113
L	-.065	+.252
M	-.065	+.113
N	+.065	+.113
P	+.130	.000
R	+.065	-.113
S	-.065	-.113
T	-.130	.000
U	.000	.000

Alternate PC Tail diameters are available. Refer to PC Tail Specification section starting on 229-234. Dimensional data for the most common insert patterns for the PCB applications are shown. For availability of other insert arrangements, please consult Conesys/Aero-Electric Connector.

Circular Connectors - PCB Contacts

MIL-DTL-26482 Series II

Insert Arrangements



Connector Type	MIL-DTL-26482 Series II	Number of Contacts	Contact Size	Service Rating
Insert Designation	14-19	19	20	I

Front face of pin insert shown

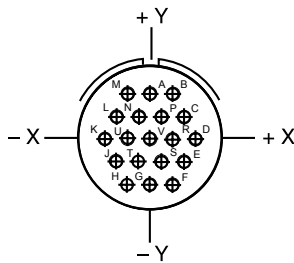

Contact Locations		
Contact Position	Location	
	X-Axis	Y-Axis
A	.000	+.225
B	+.130	+.225
C	.195	+.113
D	+.260	.000
E	+.195	-.113
F	+.130	-.225
G	.000	-.225
H	-.130	-.225
J	-.195	-.113

Contact Locations		
Contact Position	Location	
	X-Axis	Y-Axis
K	-.260	.000
L	-.195	+.113
M	-.130	+.225
N	-.065	+.113
P	+.065	+.113
R	+.130	.000
S	+.065	-.113
T	-.065	-.113
U	-.130	.000
V	.000	.000

Connector Type	MIL-DTL-26482 Series II	Number of Contacts	Contact Size	Service Rating
Insert Designation	16-8	8	16	II

Front face of pin insert shown

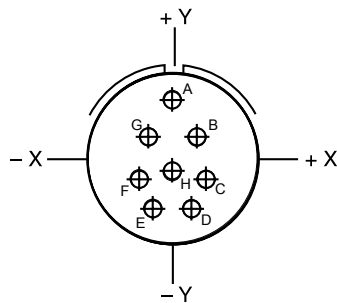

Contact Locations		
Contact Position	Location	
	X-Axis	Y-Axis
A	.000	+.236
B	+.128	+.086
C	+.230	-.078
D	+.094	-.216
E	-.094	-.216
F	-.230	-.078
G	-.128	+.086
H	.000	-.052

Alternate PC Tail diameters are available. Refer to PC Tail Specification section starting on 229-234. Dimensional data for the most common insert patterns for the PCB applications are shown. For availability of other insert arrangements, please consult Conesys/Aero-Electric Connector.



Connector Type	MIL-DTL-26482 Series II	Number of Contacts	Contact Size	Service Rating
Insert Designation	16-26	26	20	I

Front face of pin insert shown

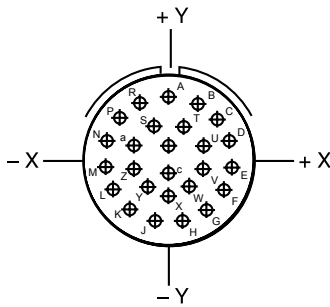

Contact Locations		
Contact Position	Location	
	X-Axis	Y-Axis
A	.000	+.321
B	+.131	+.293
C	+.239	+.214
D	+.305	+.099
E	+.319	-.034
F	+.278	-.161
G	+.189	-.260
H	+.067	-.314
J	-.067	-.314
K	-.189	-.260
L	-.278	-.161
M	-.319	-.034
N	-.305	+.099

Contact Locations		
Contact Position	Location	
	X-Axis	Y-Axis
P	-.239	+.214
R	-.131	+.293
S	-.070	+.177
T	+.070	+.177
U	+.175	+.094
V	+.178	-.036
W	+.119	-.151
X	.000	-.203
Y	-.119	-.151
Z	-.178	-.036
a	-.175	+.094
b	.000	+.065
c	.000	-.065

Connector Type	MIL-DTL-26482 Series II	Number of Contacts	Contact Size	Service Rating
Insert Designation	18-11	8	12	I

Front face of pin insert shown

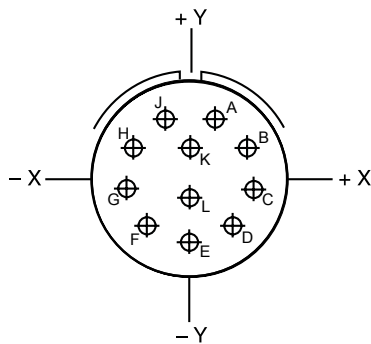

Contact Locations		
Contact Position	Location	
	X-Axis	Y-Axis
1	+.105	+.260
2	+.250	+.132
3	+.275	-.053
4	+.179	-.215
5	.000	-.281
6	-.179	-.215
7	-.275	-.053
8	-.250	+.132
9	-.105	+.260
10	.000	+.105
11	.000	-.092

Alternate PC Tail diameters are available. Refer to PC Tail Specification section starting on 229-234. Dimensional data for the most common insert patterns for the PCB applications are shown. For availability of other insert arrangements, please consult Conesys/Aero-Electric Connector.

Circular Connectors - PCB Contacts

MIL-DTL-26482 Series II

Insert Arrangements



Connector Type	MIL-DTL-26482 Series II	Number of Contacts	Contact Size	Service Rating
Insert Designation	18-32	32	20	I

Front face of pin insert shown

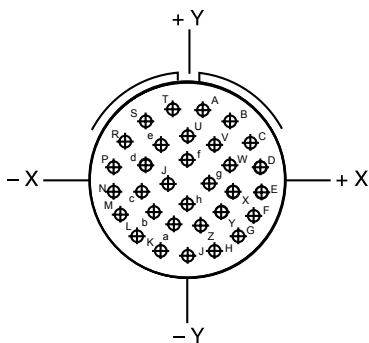

Contact Position	Location	
	X-Axis	Y-Axis
A	+066	+353
B	+189	+305
C	+286	+217
D	+345	+098
E	+357	-.033
F	+321	-.160
G	+242	-.265
H	+130	-.335
J	.000	-.359
K	-.130	-.335
L	-.242	-.265
M	-.321	-.160
N	-.357	-.033
P	-.345	+098
R	-.286	+217
S	-.189	+305

Contact Position	Location	
	X-Axis	Y-Axis
T	-.066	+353
U	.000	+230
V	+124	+193
W	+209	+095
X	+228	-.033
Y	+174	-.151
Z	+065	-.221
a	-.065	-.221
b	-.174	-.151
c	-.228	-.033
d	-.209	+095
e	-.124	+193
f	.000	+096
g	+096	.000
h	.000	-.096
i	-.096	.000

Connector Type	MIL-DTL-26482 Series II	Number of Contacts	Contact Size	Service Rating
Insert Designation	20-16	16	16	II

Front face of pin insert shown

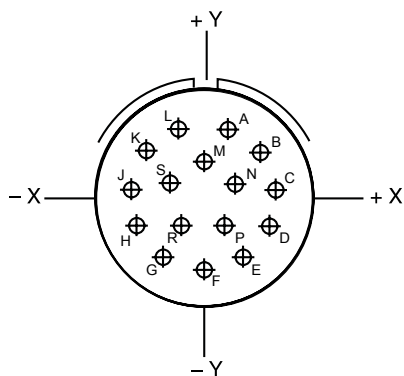

Contact Position	Location	
	X-Axis	Y-Axis
A	+118	+322
B	+271	+211
C	+341	+036
D	+308	-.150
E	+182	-.290
F	.000	-.343
G	-.182	-.290
H	-.308	-.150

Contact Position	Location	
	X-Axis	Y-Axis
J	-.341	+036
K	-.271	+211
L	-.118	+322
M	.000	+175
N	+154	+062
P	+094	-.122
R	-.094	-.122
S	-.154	+062

Alternate PC Tail diameters are available. Refer to PC Tail Specification section starting on 229-234. Dimensional data for the most common insert patterns for the PCB applications are shown. For availability of other insert arrangements, please consult Conesys/Aero-Electric Connector.

Connector Type	MIL-DTL-26482 Series II	Number of Contacts	Contact Size	Service Rating
Insert Designation	20-24	24	20	I

Front face of pin insert shown

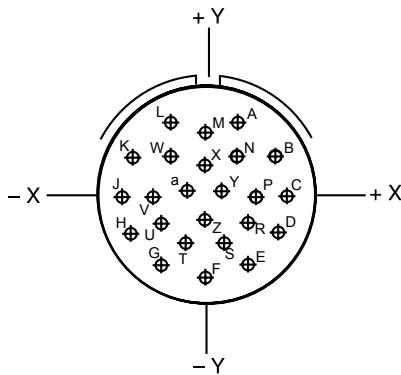

Contact Position	Location	
	X-Axis	Y-Axis
A	+ .175	+ .375
B	+ .350	+ .200
C	+ .400	.000
D	+ .350	- .200
E	+ .200	- .350
F	.000	- .400
G	- .200	- .350
H	- .350	- .200
J	- .400	.000
K	- .350	+ .200
L	- .175	+ .375
M	.000	+ .300

Contact Position	Location	
	X-Axis	Y-Axis
N	+ .150	+ .200
P	+ .250	.000
R	+ .200	- .150
S	+ .075	- .250
T	- .075	- .250
U	- .200	- .150
V	- .250	.000
W	- .150	+ .200
X	.000	+ .150
Y	+ .100	+ .025
Z	.000	- .100
a	- .100	+ .025

Connector Type	MIL-DTL-26482 Series II	Number of Contacts	Contact Size	Service Rating
Insert Designation	20-41	41	20	I

Front face of pin insert shown

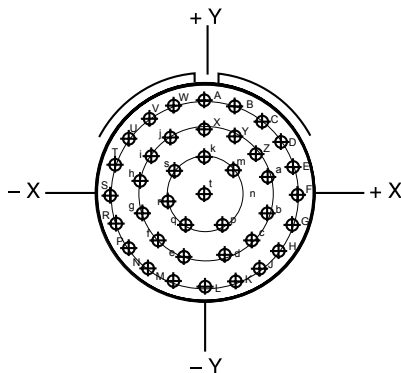

Contact Position	Location	
	X-Axis	Y-Axis
A	.000	+ .418
B	+ .129	+ .397
C	+ .245	+ .338
D	+ .338	+ .245
E	+ .397	+ .129
F	+ .418	.000
G	+ .397	- .129
H	+ .338	- .245
J	+ .245	- .338
K	+ .129	- .397
L	.000	- .418
M	- .129	- .397
N	- .245	- .338
P	- .338	- .245
R	- .397	- .129
S	- .418	.000
T	- .397	+ .129
U	- .338	+ .245
V	- .245	+ .338
W	- .129	+ .397
X	.000	+ .284

Contact Position	Location	
	X-Axis	Y-Axis
Y	+ .132	+ .251
Z	+ .233	+ .161
a	+ .281	+ .034
b	+ .265	- .101
c	+ .188	- .212
d	+ .068	- .275
e	- .068	- .275
f	- .188	- .212
g	- .265	- .101
h	- .281	+ .034
i	- .233	+ .161
j	- .132	+ .251
k	.000	+ .150
m	+ .117	+ .094
n	+ .146	- .033
p	+ .065	- .135
q	- .065	- .135
r	- .146	- .033
s	- .117	+ .094
t	.000	.000

Alternate PC Tail diameters are available. Refer to PC Tail Specification section starting on 229-234. Dimensional data for the most common insert patterns for the PCB applications are shown. For availability of other insert arrangements, please consult Conesys/Aero-Electric Connector.

Circular Connectors - PCB Contacts

MIL-DTL-26482 Series II

Insert Arrangements



Connector Type	MIL-DTL-26482 Series II	Number of Contacts	Contact Size	Service Rating
Insert Designation	22-21	12	12	I

PCB

Front face of pin insert shown

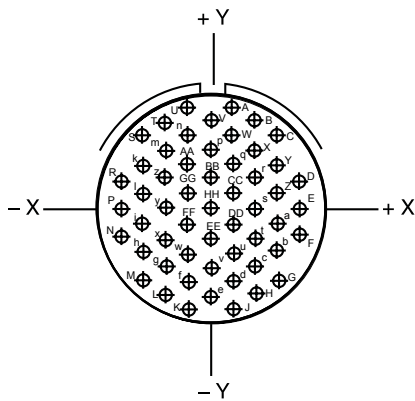

Contact Locations		
Contact Position	Location	
	X-Axis	Y-Axis
A	+128	+385
B	+289	+285
C	+386	+123
D	+400	-.065
E	+328	-.239
F	+183	-.362
G	.000	-.406
H	-.183	-.362
J	-.328	-.239
K	-.400	-.065
L	-.386	+123
M	-.289	+285
N	-.128	+385
P	.000	+245
R	+160	+146
S	+214	-.035
T	+094	-.194
U	-.094	-.194
V	-.214	-.035
W	-.160	+146
X	.000	.000

Alternate PC Tail diameters are available. Refer to PC Tail Specification section starting on 229-234. Dimensional data for the most common insert patterns for the PCB applications are shown. For availability of other insert arrangements, please consult Conesys/Aero-Electric Connector.



Circular Connectors - PCB Contacts
MIL-DTL-26482 Series II
Insert Arrangements

Connector Type	MIL-DTL-26482 Series II	Number of Contacts	Contact Size	Service Rating
Insert Designation	22-55	55	20	I

Front face of pin insert shown

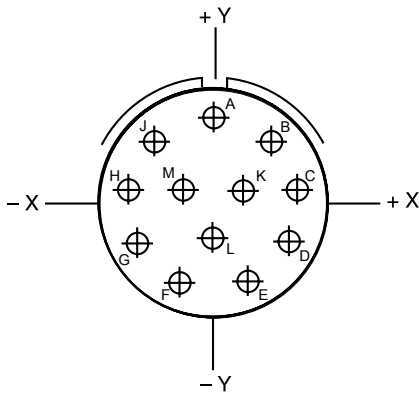

Contact Locations		
Contact Position	Location	
	X-Axis	Y-Axis
A	+112	+455
B	+225	+390
C	+336	+325
D	+450	+130
E	+450	.000
F	+450	-130
G	+336	-325
H	+225	-390
J	+112	-455
K	-112	-455
L	-225	-390
M	-336	-325
N	-450	-130
P	-450	.000
R	-450	+130
S	-336	+325
T	-225	+390
U	-112	+455
V	.000	+390
W	+112	+325
X	+225	+260
Y	+336	+195
Z	+336	+065
a	+336	-065
b	+336	-195
c	+225	-260
d	+112	-325
e	.000	-390
f	-112	-325

Contact Locations		
Contact Position	Location	
	X-Axis	Y-Axis
g	-.225	-.260
h	-.336	-.195
i	-.336	-.065
j	-.336	+065
k	-.336	+195
m	-.225	+260
n	-.112	+325
p	.000	+260
q	+112	+195
r	+225	+130
s	+225	.000
t	+225	-.130
u	+112	-.195
v	.000	-.260
w	-.112	-.195
x	-.225	-.130
y	-.225	.000
z	-.225	+130
AA	-.112	+195
BB	.000	+130
CC	+112	+065
DD	+112	-.065
EE	.000	-.130
FF	-.112	-.065
GG	-.112	+065
HH	.000	.000

PCB

Alternate PC Tail diameters are available. Refer to PC Tail Specification section starting on 229-234. Dimensional data for the most common insert patterns for the PCB applications are shown. For availability of other insert arrangements, please consult Conesys/Aero-Electric Connector.

Circular Connectors - PCB Contacts

MIL-DTL-26482 Series II

Insert Arrangements



Connector Type	MIL-DTL-26482 Series II	Number of Contacts	Contact Size	Service Rating
Insert Designation	24-31	31	16	I

PCB

Front face of pin insert shown

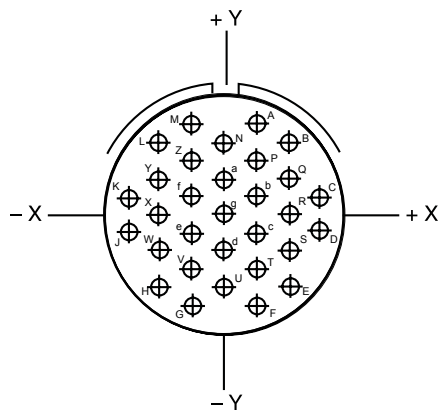

Contact Locations		
Contact Position	Location	
	X-Axis	Y-Axis
A	+158	+455
B	+316	+364
C	+474	+091
D	+474	-.091
E	+316	-.364
F	+158	-.455
G	-.158	-.455
H	-.316	-.364
J	-.474	-.091
K	-.474	+091
L	-.316	+364
M	-.158	-.455
N	.000	+364
P	+158	+273
Q	+316	+182
R	+316	.000
S	+316	-.182
T	+158	-.273
U	.000	-.364
V	-.158	-.273
W	-.316	-.182
X	-.316	.000
Y	-.316	+182
Z	-.158	+273
a	.000	+182
b	+158	+091
c	+158	-.091
d	.000	-.182
e	-.158	-.091
f	-.158	+091
g	.000	.000

Alternate PC Tail diameters are available. Refer to PC Tail Specification section starting on 229-234. Dimensional data for the most common insert patterns for the PCB applications are shown. For availability of other insert arrangements, please consult Conesys/Aero-Electric Connector.



Connector Type	MIL-DTL-26482 Series II	Number of Contacts	Contact Size	Service Rating
Insert Designation	24-61	61	20	I

Front face of pin insert shown

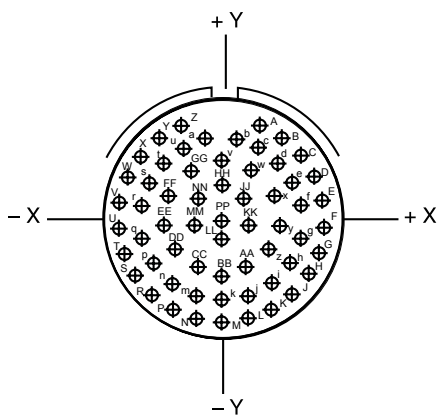

Contact Locations		
Contact Position	Location	
	X-Axis	Y-Axis
A	+196	+500
B	+314	+435
C	+413	+343
D	+485	+230
E	+527	+101
F	+536	-.030
G	+511	-.164
H	+454	-.287
J	+368	-.391
K	+259	-.470
L	+134	-.519
M	.000	-.537
N	-.134	-.519
P	-.259	-.470
R	-.368	-.391
S	-.454	-.287
T	-.511	-.164
U	-.536	-.030
V	-.527	+101
W	-.485	+230

Contact Locations		
Contact Position	Location	
	X-Axis	Y-Axis
X	-.413	+.343
Y	-.314	+.435
Z	-.196	+.500
a	-.068	+.454
b	+.068	+.454
c	+.173	+.363
d	+.285	+.283
e	+.362	+.175
f	+.399	+.046
g	+.392	-.088
h	+.341	-.213
i	+.251	-.314
j	+.133	-.379
k	.000	-.402
m	-.133	-.379
n	-.251	-.314
p	-.341	-.213
q	-.392	-.088
r	-.399	+.046
s	-.362	+.175
t	-.285	+.283
u	-.173	+.363
v	.000	+.338
w	+.147	+.223
x	+.237	+.122
y	+.267	-.010
z	+.228	-.139
AA	+.131	-.233
BB	.000	-.267
CC	-.131	-.233
DD	-.228	-.139
EE	-.267	-.010
FF	-.237	+.122
GG	-.147	+.223
HH	.000	+.200
JJ	+.105	+.094
KK	+.135	-.041
LL	.000	-.132
MM	-.135	-.041
NN	-.105	+.094
PP	.000	.000

Alternate PC Tail diameters are available. Refer to PC Tail Specification section starting on 229-234. Dimensional data for the most common insert patterns for the PCB applications are shown. For availability of other insert arrangements, please consult Conesys/Aero-Electric Connector.

Circular Connectors - PCB Contacts

MIL-DTL-38999 Series I, II, III, and MIL-DTL-26482 Series II

PC Tail Lengths



Standard contact length and diameter is identified on the main page for each PCB connector series/style (see pages 167 to 192 and 209 to 214). To choose an alternate contact length or diameter, locate the preferred length and diameter of contact in the tables on pages 229 Thru 234 select the modification code dash number specified for that contact configuration. Add the modification code to the end of the connector part number created from the part number builder.

For example: A connector using size 22 pin contacts in the standard configuration (standard diameter and length) would not require any modification to the part number. However, if a size 22 pin contact with a diameter of 0.019" and pc-tail length of 0.110" is required, the connector part number needs to be specified with a -1101 added to the end of the part number to specify the specific length and diameter required by the designer. Consult factory for further information or assistance.

Contact	Modification Code	Diameter	Tolerance	Tail Length	Tolerance
Size 22 Pin	Standard Config.	0.019	+/- .001	0.250	+/- .020
Size 22 Pin	-1101	0.019	+/- .001	0.110	+/- .020
Size 22 Pin	-1102	0.019	+/- .001	0.130	+/- .020
Size 22 Pin	-1103	0.019	+/- .001	0.150	+/- .020
Size 22 Pin	-1104	0.019	+/- .001	0.170	+/- .020
Size 22 Pin	-1105	0.019	+/- .001	0.190	+/- .020
Size 22 Pin	-1106	0.019	+/- .001	0.210	+/- .020
Size 22 Pin	-1107	0.019	+/- .001	0.230	+/- .020
Size 22 Pin	-1108	0.019	+/- .001	0.270	+/- .020
Size 22 Pin	-1109	0.019	+/- .001	0.290	+/- .020
Size 22 Pin	-1110	0.019	+/- .001	0.310	+/- .020
Size 22 Pin	-1111	0.019	+/- .001	0.330	+/- .020
Size 22 Pin	-1112	0.019	+/- .001	0.350	+/- .020
Size 22 Pin	-1113	0.019	+/- .001	0.370	+/- .020
Size 22 Pin	-1114	0.019	+/- .001	0.390	+/- .020
Size 22 Pin	-1115	0.019	+/- .001	0.410	+/- .020
Size 22 Pin	-1116	0.019	+/- .001	0.430	+/- .020
Size 22 Pin	-1117	0.019	+/- .001	0.450	+/- .020
Size 22 Pin	-1118	0.019	+/- .001	0.470	+/- .020
Size 22 Pin	-1119	0.019	+/- .001	0.490	+/- .020
Size 22 Pin	-1120	0.019	+/- .001	0.510	+/- .020
Size 22 Pin	-1121	0.025	+/- .001	0.110	+/- .020
Size 22 Pin	-1122	0.025	+/- .001	0.130	+/- .020
Size 22 Pin	-1123	0.025	+/- .001	0.150	+/- .020
Size 22 Pin	-1124	0.025	+/- .001	0.170	+/- .020
Size 22 Pin	-1125	0.025	+/- .001	0.190	+/- .020
Size 22 Pin	-1126	0.025	+/- .001	0.210	+/- .020
Size 22 Pin	-1127	0.025	+/- .001	0.230	+/- .020
Size 22 Pin	-1128	0.025	+/- .001	0.250	+/- .020
Size 22 Pin	-1129	0.025	+/- .001	0.270	+/- .020
Size 22 Pin	-1130	0.025	+/- .001	0.290	+/- .020
Size 22 Pin	-1131	0.025	+/- .001	0.310	+/- .020
Size 22 Pin	-1132	0.025	+/- .001	0.330	+/- .020
Size 22 Pin	-1133	0.025	+/- .001	0.350	+/- .020
Size 22 Pin	-1134	0.025	+/- .001	0.370	+/- .020
Size 22 Pin	-1135	0.025	+/- .001	0.390	+/- .020
Size 22 Pin	-1136	0.025	+/- .001	0.410	+/- .020
Size 22 Pin	-1137	0.025	+/- .001	0.430	+/- .020
Size 22 Pin	-1138	0.025	+/- .001	0.450	+/- .020
Size 22 Pin	-1139	0.025	+/- .001	0.470	+/- .020
Size 22 Pin	-1140	0.025	+/- .001	0.490	+/- .020
Size 22 Pin	-1141	0.025	+/- .001	0.510	+/- .020

PCB



Circular Connectors - PCB Contacts MIL-DTL-38999 Series I, II, III, and MIL-DTL-26482 Series II PC Tail Lengths

Standard contact length and diameter is identified on the main page for each PCB connector series/style (see pages 167 to 192 and 209 to 214). To choose an alternate contact length or diameter, locate the preferred length and diameter of contact in the tables on pages 229 Thru 234 select the modification code dash number specified for that contact configuration. Add the modification code to the end of the connector part number created from the part number builder.

For example: A connector using size 22 pin contacts in the standard configuration (standard diameter and length) would not require any modification to the part number. However, if a size 22 pin contact with a diameter of .0019" and pc-tail length of 0.110" is required, the connector part number needs to be specified with a -1101 added to the end of the part number to specify the specific length and diameter required by the designer. Consult factory for further information or assistance.

Contact	Modification Code	Diameter	Tolerance	Tail Length	Tolerance
Size 22 Socket	Standard Config.	0.019	+/- .001	0.250	+/- .020
Size 22 Socket	-1401	0.019	+/- .001	0.110	+/- .020
Size 22 Socket	-1402	0.019	+/- .001	0.130	+/- .020
Size 22 Socket	-1403	0.019	+/- .001	0.150	+/- .020
Size 22 Socket	-1404	0.019	+/- .001	0.170	+/- .020
Size 22 Socket	-1405	0.019	+/- .001	0.190	+/- .020
Size 22 Socket	-1406	0.019	+/- .001	0.210	+/- .020
Size 22 Socket	-1407	0.019	+/- .001	0.230	+/- .020
Size 22 Socket	-1408	0.019	+/- .001	0.270	+/- .020
Size 22 Socket	-1409	0.019	+/- .001	0.290	+/- .020
Size 22 Socket	-1410	0.019	+/- .001	0.310	+/- .020
Size 22 Socket	-1411	0.019	+/- .001	0.330	+/- .020
Size 22 Socket	-1412	0.019	+/- .001	0.350	+/- .020
Size 22 Socket	-1413	0.019	+/- .001	0.370	+/- .020
Size 22 Socket	-1414	0.019	+/- .001	0.390	+/- .020
Size 22 Socket	-1415	0.019	+/- .001	0.410	+/- .020
Size 22 Socket	-1416	0.019	+/- .001	0.430	+/- .020
Size 22 Socket	-1417	0.019	+/- .001	0.450	+/- .020
Size 22 Socket	-1418	0.019	+/- .001	0.470	+/- .020
Size 22 Socket	-1419	0.019	+/- .001	0.490	+/- .020
Size 22 Socket	-1420	0.019	+/- .001	0.510	+/- .020
Size 22 Socket	-1421	0.025	+/- .001	0.110	+/- .020
Size 22 Socket	-1422	0.025	+/- .001	0.130	+/- .020
Size 22 Socket	-1423	0.025	+/- .001	0.150	+/- .020
Size 22 Socket	-1424	0.025	+/- .001	0.170	+/- .020
Size 22 Socket	-1425	0.025	+/- .001	0.190	+/- .020
Size 22 Socket	-1426	0.025	+/- .001	0.210	+/- .020
Size 22 Socket	-1427	0.025	+/- .001	0.230	+/- .020
Size 22 Socket	-1428	0.025	+/- .001	0.250	+/- .020
Size 22 Socket	-1429	0.025	+/- .001	0.270	+/- .020
Size 22 Socket	-1430	0.025	+/- .001	0.290	+/- .020
Size 22 Socket	-1431	0.025	+/- .001	0.310	+/- .020
Size 22 Socket	-1432	0.025	+/- .001	0.330	+/- .020
Size 22 Socket	-1433	0.025	+/- .001	0.350	+/- .020
Size 22 Socket	-1434	0.025	+/- .001	0.370	+/- .020
Size 22 Socket	-1435	0.025	+/- .001	0.390	+/- .020
Size 22 Socket	-1436	0.025	+/- .001	0.410	+/- .020
Size 22 Socket	-1437	0.025	+/- .001	0.430	+/- .020
Size 22 Socket	-1438	0.025	+/- .001	0.450	+/- .020
Size 22 Socket	-1439	0.025	+/- .001	0.470	+/- .020
Size 22 Socket	-1440	0.025	+/- .001	0.490	+/- .020
Size 22 Socket	-1441	0.025	+/- .001	0.510	+/- .020

PCB

Circular Connectors - PCB Contacts

MIL-DTL-38999 Series I, II, III, and MIL-DTL-26482 Series II

PC Tail Lengths



Standard contact length and diameter is identified on the main page for each PCB connector series/style (see pages 167 to 192 and 209 to 214. To choose an alternate contact length or diameter, locate the preferred length and diameter of contact in the tables on pages 229 Thru 234 select the modification code dash number specified for that contact configuration. Add the modification code to the end of the connector part number created from the part number builder.

For example: A connector using size 22 pin contacts in the standard configuration (standard diameter and length) would not require any modification to the part number. However, if a size 22 pin contact with a diameter of .0019" and pc-tail length of 0.110" is required, the connector part number needs to be specified with a -1101 added to the end of the part number to specify the specific length and diameter required by the designer. Consult factory for further information or assistance.

Contact	Modification Code	Diameter	Tolerance	Tail Length	Tolerance
Size 20 Pin	Standard Config.	0.019	+/- .001	0.250	+/- .020
Size 20 Pin	-1201	0.019	+/- .001	0.110	+/- .020
Size 20 Pin	-1202	0.019	+/- .001	0.130	+/- .020
Size 20 Pin	-1203	0.019	+/- .001	0.150	+/- .020
Size 20 Pin	-1204	0.019	+/- .001	0.170	+/- .020
Size 20 Pin	-1205	0.019	+/- .001	0.190	+/- .020
Size 20 Pin	-1206	0.019	+/- .001	0.210	+/- .020
Size 20 Pin	-1207	0.019	+/- .001	0.230	+/- .020
Size 20 Pin	-1208	0.019	+/- .001	0.270	+/- .020
Size 20 Pin	-1209	0.019	+/- .001	0.290	+/- .020
Size 20 Pin	-1210	0.019	+/- .001	0.310	+/- .020
Size 20 Pin	-1211	0.019	+/- .001	0.330	+/- .020
Size 20 Pin	-1212	0.019	+/- .001	0.350	+/- .020
Size 20 Pin	-1213	0.019	+/- .001	0.370	+/- .020
Size 20 Pin	-1214	0.019	+/- .001	0.390	+/- .020
Size 20 Pin	-1215	0.019	+/- .001	0.410	+/- .020
Size 20 Pin	-1216	0.019	+/- .001	0.430	+/- .020
Size 20 Pin	-1217	0.019	+/- .001	0.450	+/- .020
Size 20 Pin	-1218	0.019	+/- .001	0.470	+/- .020
Size 20 Pin	-1219	0.019	+/- .001	0.490	+/- .020
Size 20 Pin	-1220	0.019	+/- .001	0.510	+/- .020
Size 20 Pin	-1221	0.025	+/- .001	0.110	+/- .020
Size 20 Pin	-1222	0.025	+/- .001	0.130	+/- .020
Size 20 Pin	-1223	0.025	+/- .001	0.150	+/- .020
Size 20 Pin	-1224	0.025	+/- .001	0.170	+/- .020
Size 20 Pin	-1225	0.025	+/- .001	0.190	+/- .020
Size 20 Pin	-1226	0.025	+/- .001	0.210	+/- .020
Size 20 Pin	-1227	0.025	+/- .001	0.230	+/- .020
Size 20 Pin	-1228	0.025	+/- .001	0.250	+/- .020
Size 20 Pin	-1229	0.025	+/- .001	0.270	+/- .020
Size 20 Pin	-1230	0.025	+/- .001	0.290	+/- .020
Size 20 Pin	-1231	0.025	+/- .001	0.310	+/- .020
Size 20 Pin	-1232	0.025	+/- .001	0.330	+/- .020
Size 20 Pin	-1233	0.025	+/- .001	0.350	+/- .020
Size 20 Pin	-1234	0.025	+/- .001	0.370	+/- .020
Size 20 Pin	-1235	0.025	+/- .001	0.390	+/- .020
Size 20 Pin	-1236	0.025	+/- .001	0.410	+/- .020
Size 20 Pin	-1237	0.025	+/- .001	0.430	+/- .020
Size 20 Pin	-1238	0.025	+/- .001	0.450	+/- .020
Size 20 Pin	-1239	0.025	+/- .001	0.470	+/- .020
Size 20 Pin	-1240	0.025	+/- .001	0.490	+/- .020
Size 20 Pin	-1241	0.025	+/- .001	0.510	+/- .020

PCB



Circular Connectors - PCB Contacts

MIL-DTL-38999 Series I, II, III, and MIL-DTL-26482 Series II

PC Tail Lengths

Standard contact length and diameter is identified on the main page for each PCB connector series/style (see pages 167 to 192 and 209 to 214. To choose an alternate contact length or diameter, locate the preferred length and diameter of contact in the tables on pages 229 Thru 234 select the modification code dash number specified for that contact configuration. Add the modification code to the end of the connector part number created from the part number builder.

For example: A connector using size 22 pin contacts in the standard configuration (standard diameter and length) would not require any modification to the part number. However, if a size 22 pin contact with a diameter of .0019" and pc-tail length of 0.110" is required, the connector part number needs to be specified with a -1101 added to the end of the part number to specify the specific length and diameter required by the designer. Consult factory for further information or assistance.

Contact	Modification Code	Diameter	Tolerance	Tail Length	Tolerance
Size 20 Socket	Standard Config.	0.019	+/- .001	0.250	+/- .020
Size 20 Socket	-1501	0.019	+/- .001	0.110	+/- .020
Size 20 Socket	-1502	0.019	+/- .001	0.130	+/- .020
Size 20 Socket	-1503	0.019	+/- .001	0.150	+/- .020
Size 20 Socket	-1504	0.019	+/- .001	0.170	+/- .020
Size 20 Socket	-1505	0.019	+/- .001	0.190	+/- .020
Size 20 Socket	-1506	0.019	+/- .001	0.210	+/- .020
Size 20 Socket	-1507	0.019	+/- .001	0.230	+/- .020
Size 20 Socket	-1508	0.019	+/- .001	0.270	+/- .020
Size 20 Socket	-1509	0.019	+/- .001	0.290	+/- .020
Size 20 Socket	-1510	0.019	+/- .001	0.310	+/- .020
Size 20 Socket	-1511	0.019	+/- .001	0.330	+/- .020
Size 20 Socket	-1512	0.019	+/- .001	0.350	+/- .020
Size 20 Socket	-1513	0.019	+/- .001	0.370	+/- .020
Size 20 Socket	-1514	0.019	+/- .001	0.390	+/- .020
Size 20 Socket	-1515	0.019	+/- .001	0.410	+/- .020
Size 20 Socket	-1516	0.019	+/- .001	0.430	+/- .020
Size 20 Socket	-1517	0.019	+/- .001	0.450	+/- .020
Size 20 Socket	-1518	0.019	+/- .001	0.470	+/- .020
Size 20 Socket	-1519	0.019	+/- .001	0.490	+/- .020
Size 20 Socket	-1520	0.019	+/- .001	0.510	+/- .020
Size 20 Socket	-1521	0.025	+/- .001	0.110	+/- .020
Size 20 Socket	-1522	0.025	+/- .001	0.130	+/- .020
Size 20 Socket	-1523	0.025	+/- .001	0.150	+/- .020
Size 20 Socket	-1524	0.025	+/- .001	0.170	+/- .020
Size 20 Socket	-1525	0.025	+/- .001	0.190	+/- .020
Size 20 Socket	-1526	0.025	+/- .001	0.210	+/- .020
Size 20 Socket	-1527	0.025	+/- .001	0.230	+/- .020
Size 20 Socket	-1528	0.025	+/- .001	0.250	+/- .020
Size 20 Socket	-1529	0.025	+/- .001	0.270	+/- .020
Size 20 Socket	-1530	0.025	+/- .001	0.290	+/- .020
Size 20 Socket	-1531	0.025	+/- .001	0.310	+/- .020
Size 20 Socket	-1532	0.025	+/- .001	0.330	+/- .020
Size 20 Socket	-1533	0.025	+/- .001	0.350	+/- .020
Size 20 Socket	-1534	0.025	+/- .001	0.370	+/- .020
Size 20 Socket	-1535	0.025	+/- .001	0.390	+/- .020
Size 20 Socket	-1536	0.025	+/- .001	0.410	+/- .020
Size 20 Socket	-1537	0.025	+/- .001	0.430	+/- .020
Size 20 Socket	-1538	0.025	+/- .001	0.450	+/- .020
Size 20 Socket	-1539	0.025	+/- .001	0.470	+/- .020
Size 20 Socket	-1540	0.025	+/- .001	0.490	+/- .020
Size 20 Socket	-1541	0.025	+/- .001	0.510	+/- .020

Circular Connectors - PCB Contacts

MIL-DTL-38999 Series I, II, III, and MIL-DTL-26482 Series II

PC Tail Lengths



Standard contact length and diameter is identified on the main page for each PCB connector series/style (see pages 167 to 192 and 209 to 214. To choose an alternate contact length or diameter, locate the preferred length and diameter of contact in the tables on pages 229 Thru 234 select the modification code dash number specified for that contact configuration. Add the modification code to the end of the connector part number created from the part number builder.

For example: A connector using size 22 pin contacts in the standard configuration (standard diameter and length) would not require any modification to the part number. However, if a size 22 pin contact with a diameter of .0019" and pc-tail length of 0.110" is required, the connector part number needs to be specified with a -1101 added to the end of the part number to specify the specific length and diameter required by the designer. Consult factory for further information or assistance.

Contact	Modification Code	Diameter	Tolerance	Tail Length	Tolerance
Size 16 Pin	Standard Config.	0.062	+/- .001	0.250	+/- .020
Size 16 Pin	-1301	0.062	+/- .001	0.110	+/- .020
Size 16 Pin	-1302	0.062	+/- .001	0.130	+/- .020
Size 16 Pin	-1303	0.062	+/- .001	0.150	+/- .020
Size 16 Pin	-1304	0.062	+/- .001	0.170	+/- .020
Size 16 Pin	-1305	0.062	+/- .001	0.190	+/- .020
Size 16 Pin	-1306	0.062	+/- .001	0.210	+/- .020
Size 16 Pin	-1307	0.062	+/- .001	0.230	+/- .020
Size 16 Pin	-1308	0.062	+/- .001	0.270	+/- .020
Size 16 Pin	-1309	0.062	+/- .001	0.290	+/- .020
Size 16 Pin	-1310	0.062	+/- .001	0.310	+/- .020
Size 16 Pin	-1311	0.062	+/- .001	0.330	+/- .020
Size 16 Pin	-1312	0.062	+/- .001	0.350	+/- .020
Size 16 Pin	-1313	0.062	+/- .001	0.370	+/- .020
Size 16 Pin	-1314	0.062	+/- .001	0.390	+/- .020
Size 16 Pin	-1315	0.062	+/- .001	0.410	+/- .020
Size 16 Pin	-1316	0.062	+/- .001	0.430	+/- .020
Size 16 Pin	-1317	0.062	+/- .001	0.450	+/- .020
Size 16 Pin	-1318	0.062	+/- .001	0.470	+/- .020
Size 16 Pin	-1319	0.062	+/- .001	0.490	+/- .020
Size 16 Pin	-1320	0.062	+/- .001	0.510	+/- .020
Size 16 Pin	-1321	0.040	+/- .001	0.110	+/- .020
Size 16 Pin	-1322	0.040	+/- .001	0.130	+/- .020
Size 16 Pin	-1323	0.040	+/- .001	0.150	+/- .020
Size 16 Pin	-1324	0.040	+/- .001	0.170	+/- .020
Size 16 Pin	-1325	0.040	+/- .001	0.190	+/- .020
Size 16 Pin	-1326	0.040	+/- .001	0.210	+/- .020
Size 16 Pin	-1327	0.040	+/- .001	0.230	+/- .020
Size 16 Pin	-1328	0.040	+/- .001	0.250	+/- .020
Size 16 Pin	-1329	0.040	+/- .001	0.270	+/- .020
Size 16 Pin	-1330	0.040	+/- .001	0.290	+/- .020
Size 16 Pin	-1331	0.040	+/- .001	0.310	+/- .020
Size 16 Pin	-1332	0.040	+/- .001	0.330	+/- .020
Size 16 Pin	-1333	0.040	+/- .001	0.350	+/- .020
Size 16 Pin	-1334	0.040	+/- .001	0.370	+/- .020
Size 16 Pin	-1335	0.040	+/- .001	0.390	+/- .020
Size 16 Pin	-1336	0.040	+/- .001	0.410	+/- .020
Size 16 Pin	-1337	0.040	+/- .001	0.430	+/- .020
Size 16 Pin	-1338	0.040	+/- .001	0.450	+/- .020
Size 16 Pin	-1339	0.040	+/- .001	0.470	+/- .020
Size 16 Pin	-1340	0.040	+/- .001	0.490	+/- .020
Size 16 Pin	-1341	0.040	+/- .001	0.510	+/- .020



Circular Connectors - PCB Contacts

MIL-DTL-38999 Series I, II, III, and MIL-DTL-26482 Series II

PC Tail Lengths

Standard contact length and diameter is identified on the main page for each PCB connector series/style (see pages 167 to 192 and 209 to 214. To choose an alternate contact length or diameter, locate the preferred length and diameter of contact in the tables on pages 229 Thru 234 select the modification code dash number specified for that contact configuration. Add the modification code to the end of the connector part number created from the part number builder.

For example: A connector using size 22 pin contacts in the standard configuration (standard diameter and length) would not require any modification to the part number. However, if a size 22 pin contact with a diameter of .0019" and pc-tail length of 0.110" is required, the connector part number needs to be specified with a -1101 added to the end of the part number to specify the specific length and diameter required by the designer. Consult factory for further information or assistance.

Contact	Modification Code	Diameter	Tolerance	Tail Length	Tolerance
Size 16 Socket	Standard Config.	0.062	+/- .001	0.250	+/- .020
Size 16 Socket	-1601	0.062	+/- .001	0.110	+/- .020
Size 16 Socket	-1602	0.062	+/- .001	0.130	+/- .020
Size 16 Socket	-1603	0.062	+/- .001	0.150	+/- .020
Size 16 Socket	-1604	0.062	+/- .001	0.170	+/- .020
Size 16 Socket	-1605	0.062	+/- .001	0.190	+/- .020
Size 16 Socket	-1606	0.062	+/- .001	0.210	+/- .020
Size 16 Socket	-1607	0.062	+/- .001	0.230	+/- .020
Size 16 Socket	-1608	0.062	+/- .001	0.270	+/- .020
Size 16 Socket	-1609	0.062	+/- .001	0.290	+/- .020
Size 16 Socket	-1610	0.062	+/- .001	0.310	+/- .020
Size 16 Socket	-1611	0.062	+/- .001	0.330	+/- .020
Size 16 Socket	-1612	0.062	+/- .001	0.350	+/- .020
Size 16 Socket	-1613	0.062	+/- .001	0.370	+/- .020
Size 16 Socket	-1614	0.062	+/- .001	0.390	+/- .020
Size 16 Socket	-1615	0.062	+/- .001	0.410	+/- .020
Size 16 Socket	-1616	0.062	+/- .001	0.430	+/- .020
Size 16 Socket	-1617	0.062	+/- .001	0.450	+/- .020
Size 16 Socket	-1618	0.062	+/- .001	0.470	+/- .020
Size 16 Socket	-1619	0.062	+/- .001	0.490	+/- .020
Size 16 Socket	-1620	0.062	+/- .001	0.510	+/- .020
Size 16 Socket	-1621	0.040	+/- .001	0.110	+/- .020
Size 16 Socket	-1622	0.040	+/- .001	0.130	+/- .020
Size 16 Socket	-1623	0.040	+/- .001	0.150	+/- .020
Size 16 Socket	-1624	0.040	+/- .001	0.170	+/- .020
Size 16 Socket	-1625	0.040	+/- .001	0.190	+/- .020
Size 16 Socket	-1626	0.040	+/- .001	0.210	+/- .020
Size 16 Socket	-1627	0.040	+/- .001	0.230	+/- .020
Size 16 Socket	-1628	0.040	+/- .001	0.250	+/- .020
Size 16 Socket	-1629	0.040	+/- .001	0.270	+/- .020
Size 16 Socket	-1630	0.040	+/- .001	0.290	+/- .020
Size 16 Socket	-1631	0.040	+/- .001	0.310	+/- .020
Size 16 Socket	-1632	0.040	+/- .001	0.330	+/- .020
Size 16 Socket	-1633	0.040	+/- .001	0.350	+/- .020
Size 16 Socket	-1634	0.040	+/- .001	0.370	+/- .020
Size 16 Socket	-1635	0.040	+/- .001	0.390	+/- .020
Size 16 Socket	-1636	0.040	+/- .001	0.410	+/- .020
Size 16 Socket	-1637	0.040	+/- .001	0.430	+/- .020
Size 16 Socket	-1638	0.040	+/- .001	0.450	+/- .020
Size 16 Socket	-1639	0.040	+/- .001	0.470	+/- .020
Size 16 Socket	-1640	0.040	+/- .001	0.490	+/- .020
Size 16 Socket	-1641	0.040	+/- .001	0.510	+/- .020